



DCN #88-278-007-01

FINAL
FEASIBILITY STUDY
INDUSTRIAL TRANSFORMER SUPERFUND SITE
SURFICIAL SOIL CONTAMINATION

0000638

Prepared in Cooperation with
Texas Water Commission
and
U.S. Environmental Protection Agency

Prepared By:
Radian Corporation
10675 Richmond Avenue #190
Houston, Texas 77042

Thomas Hoskings, Ph.D., P.E., Project Director
Riaz Ahmed, Ph.D., P.E., Program Manager
Karen M. Miller, Engineer

May 1988

The preparation of this report was financed by grants from the U.S. Environmental Protection Agency through the Texas Water Commission.

of Astroworld and Astrodome and finally a mix of private, single and multi-family dwellings further away from the site. The residential population is about 2,000 and a maximum daily traffic of 100,000 persons may move within the 1-mile radius due to recreational activities associated with the Astrodome and Astroworld.

000640

As early as 1971, an unincorporated company, the Industrial Transformer Company, owned and operated by Mr. Sol Lynn, was located at this site. A City of Houston inspector noticed that workers at the company poured oil out of electrical transformers being dismantled onto the ground. In the fall of 1971, Mr. Lynn was given a series of 7-day notices to confine oil and grease to his property. Subsequent inspections revealed no corrective action at the site. On September 11, 1972, the State of Texas brought suit against Mr. Sol Lynn, on charges of illegally discharging industrial waste into Brays Bayou. Mr. Lynn was ordered to pay a \$100 fine.

In the fall of 1981, a City of Houston work crew noted strong chemical odors while installing a waterline adjacent to the property owned by Mr. Lynn. The property, although was still owned by Mr. Lynn, was leased to Mr. Ken James, owner of Sila-King, a reputed chemical-supply house. An inspection later that day by representatives of Texas Water Commission and the City of Houston Department of Health showed about 75 empty drums scattered about the property at the addresses 1415, 1417 and 1419 South Loop West. Most of the drums, labeled trichloroethene, were empty and punctured.

Various regulatory agencies and the property owner collected a total of 101 soil samples and in 1984, the site was ranked for corrective action through the Superfund program October 5, 1984.

The consultant for the remedial investigation/feasibility study work, Radian Corporation, was selected on May 27, 1986. The RI/FS contract was executed on June 30, 1986. Amendment No. 1, authorizing Phase II - further

investigation and feasibility study at the ITS site, was executed October 28, 1987. As part of the RI, field work approved in the work plan was initiated on January 14, 1987.

Results of the Remedial Investigation

The remedial investigation consisted of a program of water, soil and sediment sampling completed by Radian to identify the lateral and vertical extent, concentration level, and volume of contaminants. Table 1 summarizes sample types and concentration levels of PCBs and TCE in the samples collected during the RI. The final results of the RI concerning the shallow subsurface PCB contamination indicate that approximately 0.75 acres of soil to a depth of 2 feet will require remediation.

Through a detailed analysis, the unremediated PCB contamination at the site was evaluated and identified as presenting an unacceptable public health risk to the potential receptors (or 1×10^{-3} cancer risk - see Section 9.0 of the RI). Therefore, the U.S. Environmental Protection Agency (EPA) proposes that the site be cleaned up to a level of 25 ppm PCBs in the shallow subsurface soils. This 25ppm PCB level is the recommended Toxic Substance Control Act (TSCA) cleanup value for PCB spills in industrial areas.

Statement of Problem

PCBs are the principal contaminants at the site in the surface and shallow subsurface soils and the EPA has classified PCBs as possible carcinogens. The major concern is that exposure to PCBs may impact human health and the environment. Potential exposure pathways include direct contact, surface water, groundwater and air. This FS addresses only those actions effective in remediating the shallow subsurface PCB contamination at the ITS site. An additional FS will address remediation of the deeper subsurface soils and groundwater contaminated with PCBs and TCE.

TABLE 1. SUMMARY OF SAMPLE TYPES AND RESULTS
REMEDIAL INVESTIGATION (RI)

Sample Origin	Sample Type	No. of Samples	Parameter Analyzed	** Range of Concentration Levels (ppm)	Comments
Soil & Sediment	Soil	51	PCB	0.08-220	
		4	TCE	0.02 - 2	
		1	POP		TCE:0.0018
		3	Dioxin		None Detected
Shallow Soil Boring	Soil	37	PCB	0.05-137	
		18	TCE	0.0051-150	
		4	POP		TCE:0.003-57
		1	Dioxin		None Detected
Deep Soil Boring	Soil	50	PCB	0.05-350*	
		4	TCE	0.0077-43	
		1	POP		TCE:240
Monitor Well	Soil	16	PCB	0.05-2	
		4	TCE	15-2000	
		1	POP		TCE:12
Groundwater	Water	15	TCE	0.0007-500	
		4	VPOP	1.5-320	
Stormwater	Water	7	PCB	0.17	
		2	POP		TCE:0.0026
Ambient Air	Air	6	Particles	22.0193- 123.254 ug/m ³	
			PCB		None Detected

TCE - trichloroethene
 PCB - polychlorinated biphenyls
 POP - Priority Organic Pollutants, including TCE
 VPOP - Volatile Priority Organic Pollutants

* - The highest value, 350 ppm PCBs, was observed in the uppermost foot.

** - Values have been rounded.

C00642

Feasibility Study

The cleanup limits (25 ppm PCBs and 161 ppm TCE) and site conditions were the major factors considered in reviewing the potentially applicable remedial technologies. This review generated an extensive list of appropriate remedial technologies which were combined into sixteen complete remedial packages, or alternatives. Preliminary technical and cost evaluations of the sixteen alternatives eliminated seven alternatives from further consideration, resulting in selection of nine remedial alternatives for a detailed analysis.

The final alternatives selected for the detailed analysis are:

- Alternative 1 - No Action
- Alternative 4 - Excavation and Off-Site Landfill
- Alternative 6 - Excavation, Stabilization and Off-Site Landfill
- Alternative 7 - Excavation and Off-Site Incineration
- Alternative 8 - Excavation and On-Site Incineration
- Alternative 10 - Excavation and Activated Sludge Treatment
- Alternative 11 - Excavation and Contained Landfarm
- Alternative 12 - Excavation and Chemical Treatment
- Alternative 15 - In Situ Glassification

The final alternatives are described briefly below. Table 2 presents the final alternatives along with the screening criteria and screening results. The screening criteria consist of:

- Technical Analysis - the technical analysis screens each alternative based on its performance, reliability, implementability, and safety.
- Institutional Analysis - the institutional analysis screens each alternative based on its conformance with Applicable or Relevant and Appropriate Requirements (ARARs).
- Public Health Analysis - the public health analysis provides information on the degree to which each alternative protects public health, welfare, and the environment.

- Environmental Impacts Analysis - the environmental impacts analysis evaluates each alternative based on its beneficial and adverse environmental impacts.
- Cost Analysis - the cost analysis includes detailed cost estimates and a cost sensitivity analysis.

The screening results are based on a rating system in which:

- "Low" denotes that the alternative does not meet the remedial objective.
- "Moderate" denotes that the alternative meets some or most of the remedial objectives, and
- "High" denotes that the alternative meets or exceeds the remedial objectives.

Alternative 1 - The no action alternative means that no remedial activities will occur at the site.

Alternative 4 - The excavation and off-site landfill alternative includes excavation of the contaminated, shallow subsurface soils and transport to a landfill in compliance with the Superfund Off-Site Disposal Policy.

Alternative 6 - The excavation, stabilization, and off-site landfill alternative encompasses excavating the contaminated soils, stabilizing them with cement kiln dust, and transporting the greatly increased volume of stabilized materials to an off-site landfill in compliance with Superfund Off-Site Disposal Policy.

Alternative 7 - The excavation and off-site incineration alternative includes excavating the soils and transporting them to an off-site incinerator in compliance with the Superfund Off-Site Disposal Policy.

Alternative 8 - The excavation and on-site incineration alternative encompasses excavating the contaminated, shallow subsurface soils and incinerating them in an incinerator constructed on-site. A Toxicity Characteristic Leaching Procedure Test (TCLP) must be performed in order to delist and then backfill the ash on-site.

Alternative 10 - The excavation and activated sludge alternative involves contacting the contaminated soils in a bioreactor with a microbiological slurry. The microorganisms utilize the PCBs as a food source, forming carbon dioxide and water.

Alternative 11 - The excavation and contained landfarm alternative encompasses placing the PCB-contaminated soils in a contained area where microorganisms degrade the PCBs. Tilling provides added contact between the microbes and oxygen.

Alternative 12 - Excavation and chemical treatment involves mixing the soil with an alkali polyethylene glycolate complex (APEG) in a reactor to dechlorinate the PCBs. A TCLP will be used to delist the treated soils prior to backfilling them on-site.

Alternative 15 - In situ glassification is a means of destroying organic contaminants and permanently immobilizing inorganic contaminants by directing an electric current through pairs of electrodes placed in the soil to the desired treatment depth.

C00646

FOR NUMBERING PURPOSES, THIS PAGE IS BLANK

000647

TABLE OF CONTENTS

	<u>PAGE NO.</u>
Executive Summary	
1.0 INTRODUCTION.....	1-1
1.1 Site Background Information.....	1-3
1.2 Nature and Extent of the Problem.....	1-4
1.3 Objectives of Remedial Actions.....	1-14
2.0 PRELIMINARY SCREENING OF TECHNOLOGIES.....	2-1
2.1 General Response Actions.....	2-2
2.2 Identify and Screen Technologies.....	2-4
2.2.1 No Action.....	2-4
2.2.2 Capping.....	2-4
2.2.3 Dust Control Measures.....	2-8
2.2.4 Revegetation.....	2-9
2.2.5 Diversion and Collection Systems (Rainwater).	2-9
2.2.6 Treatment of Liquid Waste Streams (Rainwater).	2-10
2.2.7 Excavation and Removal.....	2-11
2.2.8 Solidification, Stabilization or Fixation....	2-12
2.2.9 Land Disposal/Storage (On-Site and Off-Site).	2-12
2.2.10 Incineration.....	2-14
2.2.11 Non-Thermal Treatment (On-Site and Off-Site).	2-17
2.2.11.1 Catalyzed Wet Air Oxidation.....	2-17
2.2.11.2 Activated Sludge Treatment.....	2-18
2.2.11.3 Other Biological Methods.....	2-18
2.2.11.4 Chemical Treatment.....	2-19
2.2.12 In Situ Treatment.....	2-19
2.2.12.1 Solvent Finishing/Soil Washing.....	2-20
2.2.12.2 Chemical Dechlorination.....	2-20
2.2.12.3 Glassification or Vitrification....	2-21
2.2.12.4 Biodegradation.....	2-22
3.0 ALTERNATIVES DEVELOPMENT.....	3-1
3.1 Combination of Applicable Technologies Into Preliminary Remedial Alternatives.....	3-1

C00648

TABLE OF CONTENTS
(Continued)

	<u>PAGE NO.</u>
3.2 Description of Preliminary Alternatives.....	3-2
3.2.1 Alternative 1 - No Action.....	3-6
3.2.2 Alternative 2 - Capping and Revegetation.....	3-6
3.2.3 Alternative 3 - Excavation and On-Site Landfill.....	3-7
3.2.4 Alternative 4 - Excavation and Off-Site Landfill.....	3-9
3.2.5 Alternative 5 - Excavation, Stabilization, and On-Site Landfill.....	3-9
3.2.6 Alternative 6 - Excavation, Stabilization, and Off-Site Landfill.....	3-10
3.2.7 Alternative 7 - Excavation and Off-Site Incineration.....	3-10
3.2.8 Alternative 8 - Excavation and On-Site Incineration.....	3-10
3.2.9 Alternative 9 - Excavation and Catalyzed Wet Air Oxidation.....	3-11
3.2.10 Alternative 10 - Excavation and Activated Sludge Treatment.....	3-11
3.2.11 Alternative 11 - Excavation and Contained Landfarm.....	3-12
3.2.12 Alternative 12 - Excavation and Chemical Treatment.....	3-13
3.2.13 Alternative 13 - Excavation and Soil Flushing/ Solvent Washing.....	3-14
3.2.14 Alternative 14 - In Situ Chemical Dechlorina- tion.....	3-14
3.2.15 Alternative 15 - In Situ Glassification.....	3-15
3.2.16 Alternative 16 - In Situ Biodegradation.....	3-16
3.3 Surface Water Control Alternatives.....	3-16
3.3.1 Alternative 1 - No Action.....	3-17
3.3.2 Alternative 2 - Retention, Testing, and Discharge.....	3-17
3.3.3 Alternative 3 - Retention, Testing, Biologi- cal Treatment, and Discharge.....	3-18
3.3.4 Alternative 4 - Retention, Testing, Physical Treatment, and Discharge.....	3-18
3.3.5 Alternative 5 - Retention, Testing, and Dis- charge to a Publicly Owned Treatment Works..	3-19
3.3.6 Alternative 6 - Retention, Testing, Trans- port, and Deep Well Injection.....	3-19

C00649

TABLE OF CONTENTS
(Continued)

	<u>PAGE NO.</u>
3.4 Screening of Alternatives.....	3-20
3.4.1 Alternative 1 - No Action.....	3-220
3.4.2 Alternative 2 - Capping and Revegetation.....	3-23
3.4.3 Alternative 3 - Excavation and On-Site Landfill.....	3-24
3.4.4 Alternative 4 - Excavation and Off-Site Landfill.....	3-25
3.4.5 Alternative 5 - Excavation, Stabilization, and On-Site Landfill.....	3-25
3.4.6 Alternative 6 - Excavation, Stabilization and Off-Site Landfill.....	3-26
3.4.7 Alternative 7 - Excavation and Off-Site Incineration.....	3-26
3.4.8 Alternative 8 - Excavation and On-Site Incineration.....	3-27
3.4.9 Alternative 9 - Excavation and Catalyzed Wet Air Oxidation.....	3-28
3.4.10 Alternative 10 - Excavation and Activated Sludge Treatment.....	3-28
3.4.11 Alternative 11 - Excavation and Contained Landfarm.....	3-29
3.4.12 Alternative 12 - Excavation and Chemical Treatment.....	3-30
3.4.13 Alternative 13 - Excavation and Soil Flushing/ Solvent Washing.....	3-30
3.4.14 Alternative 14 - In Situ Chemical Dechlorina- tion.....	3-31
3.4.15 Alternative 15 - In Situ Glassification.....	3-31
3.4.16 Alternative 16 - In Situ Biodegradation.....	3-32
 4.0 DESCRIPTION OF ALTERNATIVES.....	 4-1
4.1 Alternative 1 - No Action.....	4-2
4.2 Alternative 4 - Excavation and Off-Site Landfill....	4-2
4.3 Alternative 6 - Excavation, Stabilization, and Off-Site Landfill.....	4-6
4.4 Alternative 7 - Excavation and Off-Site Incineration.....	4-9
4.5 Alternative 8 - Excavation and On-Site Incineration.	4-10
4.6 Alternative 10 - Excavation and Activated Sludge Treatment.....	4-14
4.7 Alternative 11 - Excavation and Contained Landfarm..	4-16
4.8 Alternative 12 - Excavation and Chemical Treatment..	4-18
4.9 Alternative 15 - In Situ Glassification.....	4-20

000650

TABLE OF CONTENTS
(Continued)

	<u>PAGE NO.</u>
5.0 DETAILED EVALUATION OF ALTERNATIVES.....	5-1
5.1 Technical Analysis.....	5-2
5.1.1 Alternative 1 - No Action.....	5-5
5.1.2 Alternative 4 - Excavation and Off-Site Landfill.....	5-5
5.1.3 Alternative 6 - Excavation, Stabilization, and Off-Site Landfill.....	5-7
5.1.4 Alternative 7 - Excavation and Off-Site Incineration.....	5-8
5.1.5 Alternative 8 - Excavation and On-Site Incineration.....	5-10
5.1.6 Alternative 10 - Excavation and Activated Sludge Treatment.....	5-11
5.1.7 Alternative 11 - Excavation and Contained Landfarm.....	5-12
5.1.8 Alternative 12 - Excavation and Chemical Treatment.....	5-14
5.1.9 Alternative 15 - In Situ Glassification.....	5-16
5.2 Institutional Analysis.....	5-18
5.2.1 Alternative 1 - No Action.....	5-20
5.2.2 Alternative 4 - Excavation and Off-Site Landfill.....	5-22
5.2.3 Alternative 6 - Excavation, Stabilization, and Off-Site Landfill.....	5-23
5.2.4 Alternative 7 - Excavation and Off-Site Incineration.....	5-23
5.2.5 Alternative 7 - Excavation and On-Site Incineration.....	5-24
5.2.6 Alternative 10 - Excavation and Activated Sludge Treatment.....	5-25
5.2.7 Alternative 11 - Excavation and Contained Landfarm.....	5-25
5.2.8 Alternative 12 - Excavation and Chemical Treatment.....	5-26
5.2.9 Alternative 15 - In Situ Glassification.....	5-26

000813-00651

TABLE OF CONTENTS
(Continued)

	<u>PAGE NO.</u>
5.6 Summary of Alternatives.....	5-48
5.6.1 Alternative 1 - No Action.....	5-48
5.6.2 Alternative 4 - Excavation and Off-Site Landfill.....	5-50
5.6.3 Alternative 6 - Excavation, Stabilization, and Off-Site Landfill.....	5-50
5.6.4 Alternative 7 - Excavation and Off-Site Incineration.....	5-50
5.6.5 Alternative 8 - Excavation and On-Site Incineration.....	5-51
5.6.6 Alternative 10 - Excavation and Activated Sludge Treatment.....	5-51
5.6.7 Alternative 11 - Excavation and Contained Landfarm.....	5-51
5.6.8 Alternative 12 - Excavation and Chemical Treatment.....	5-52
5.6.9 Alternative 15 - In Situ Glassification.....	5-52

References Cited

Appendices

000653

SECTION 1
INTRODUCTION

This report comprises the Feasibility Study (FS), which was developed in conjunction with the Remedial Investigation (RI) and the Quality Assurance/Quality Control (QA/QC) reports prepared for the Industrial Transformer Superfund (ITS) site located at the 1400 block of the South Loop West in Houston, Texas (see Figure 1-1). As discussed later, this FS concerns itself only with surficial and shallow subsurface soil contamination. Further RI work will be conducted to provide additional details on deep subsurface contamination and subsequently a separate FS study will be completed to deal with subsurface soil and groundwater contamination. The site is contaminated with polychlorinated biphenyls (PCBs) and trichloroethene (TCE) from former operations on the site. The operations contributing to the site contamination are believed to include the dismantling of electrical transformers by employees of the Industrial Transformer Company during the early 1970's and the handling of chemicals by the chemical supply company Sila-King which leased the property from 1979 to 1980.

Investigations of the site began in 1971 and continue through the RI. The first documented investigation of the site occurred in the fall of 1971 when the City of Houston Water Pollution Control Division noted that the workers at the Industrial Transformer Company poured oil out of electrical transformers onto the ground as the transformers were dismantled. Over the years from 1971 until the present, the Houston Department of Health, the Texas Water Commission (TWC), and the City of Houston Water Pollution Control Division have inspected and sampled the site. Finally in 1984, the Solid Waste Enforcement Unit of the TWC requested that the Industrial Transformer site be ranked for corrective action through the Superfund program. The RI/FS contract was executed June 30, 1986.

000000 - 00657

1-2

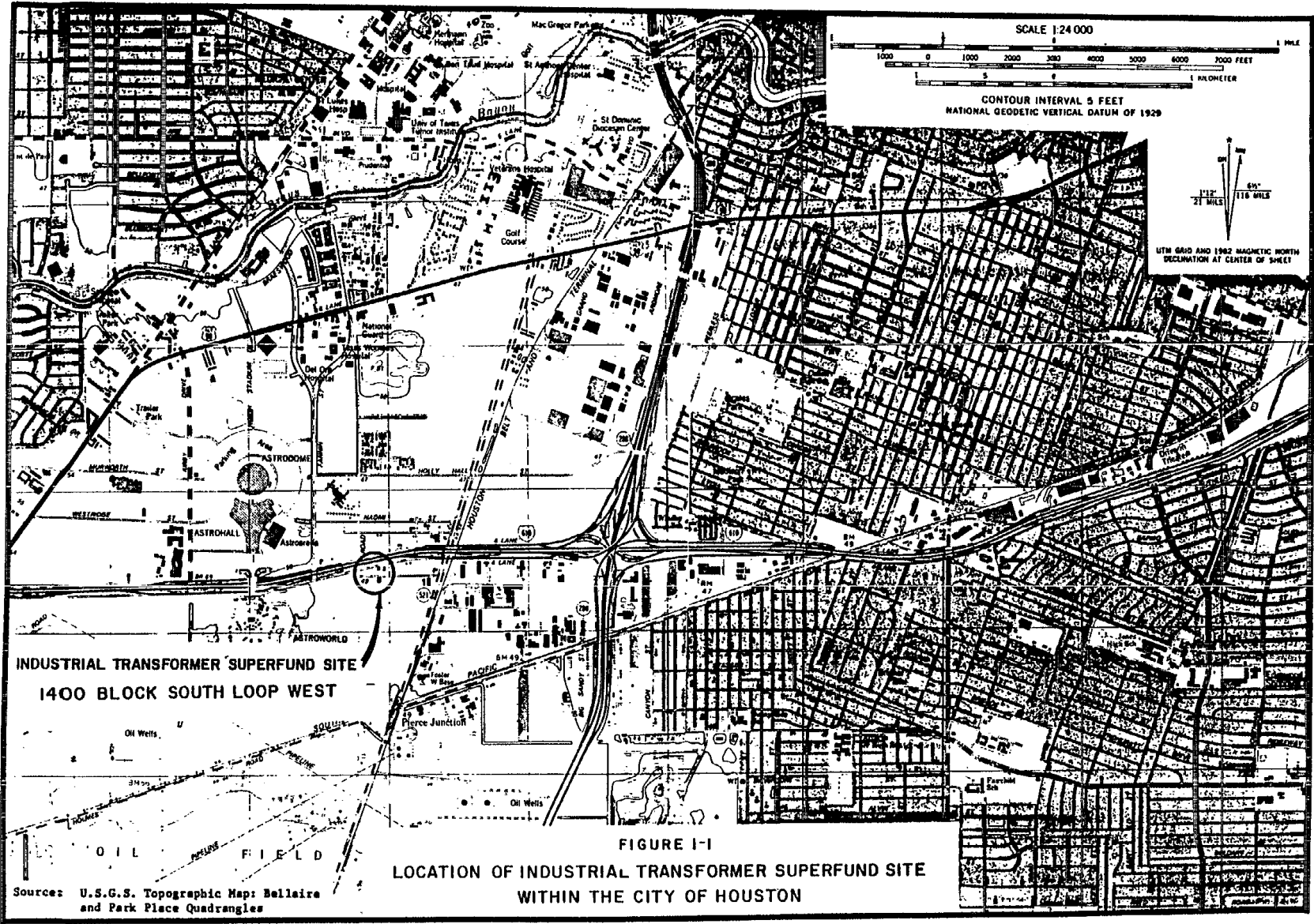

000658

On May 27, 1986, Radian Corporation was selected as the consultant to draft a work plan detailing specifics on sampling, health and safety, and QA/QC procedures for the site. Radian began the RI to obtain information on the extent of contamination in order to evaluate the impact on public health and potential remedial technologies. Finally, Radian used information obtained in the RI to prepare this FS, which evaluates the technical, environmental, and economic feasibility of the various cleanup alternatives that may be used at the site. The Environmental Protection Agency (EPA) and TWC will use the FS to recommend which cleanup alternative will be implemented.

659003

1.1 SITE BACKGROUND INFORMATION

As early as 1971, the Industrial Transformer Company, owned and operated by Mr. Sol Lynn, was located at 1415, 1417, and 1419 South Loop West in Houston, Texas. During the fall of that year, the first documented investigation of the site occurred when the City of Houston Water Pollution Control Division noted that workers of the Industrial Transformer Company poured oil out of electrical transformers onto the ground as they were dismantling the transformers. Oil and grease were observed lying on the soil and floating on standing water on-site and in the ditch adjacent to the property.

Further inspections yielded different results. An inspection of the ITS site on November 10, 1978 by a representative of the TWC showed no signs of oil spills or unauthorized discharges. Another representative of the TWC observed on January 13, 1980 old drums and an oily discharge from a drum storage area behind Sila-King, Inc., a chemical supply company operating at 1419 South Loop West. Samples collected by the City of Houston Department of Health on September 11, 1981 showed the major soil and water contaminant to be TCE. After City of Houston work crews noticed strong chemical vapors on November 14, 1981 while installing a water line along the north side of Mansard Road, representatives of the TWC and the City of Houston Department of Health investigated the site and noticed a strong TCE smell. The representatives

TABLE 1-1
SAMPLE METHODS AND PRESERVATION REQUIREMENTS

Sample	Sample Type	No.	Container	Size	Analytical		Preservation	Maximum Holding Time
					Parameter	Procedures*		
Water Well	Water	1	Glass, Teflon-lined septum	40 ml	TCE	8010	Cool, 4°C	14 days
Soil & Sediment	Soil	51	Glass, Teflon-lined cap	100 grams	PCB	8080	Cool, 4°C	14 days
		4		40 grams	TCE	8010		7 days before and
		1		100 grams	POP	8270	Cool, 4°C	40 days after
		3		100 grams	Dioxin	8280		extraction
Shallow Soil Boring	Soil	37	Glass, Teflon-lined cap	100 grams	PCB	8080	Cool, 4°C	14 days
		18		40 grams	TCE	8010		7 days before and
		4		100 grams	POP	8270	Cool, 4°C	40 days after
		1		100 grams	Dioxin	8280		extraction
Deep Soil Boring	Soil	50	Glass, Teflon-lined cap	100 grams	PCB	8080	Cool, 4°C	14 days
		4		40 grams	TCE	8010		7 days before and
		1		100 grams	POP	8270	Cool, 4°C	40 days after extraction
Monitor Well	Soil	16	Glass, Teflon-lined cap	100 grams	PCB	8080	Cool, 4°C	7 days before and
		4		40 grams	TCE	8010		40 days after
		1		100 grams	POP	8270	extraction	
Groundwater	Water	15	Glass, Teflon-lined cap	40 ml	TCE	8010	Cool, 4°C	14 days
		4		40 ml	VPOP	8240		Cool, 4°C
Storm Water	Water	7	Glass, Teflon-lined cap	1 liter	PCB	8080	Cool, 4°C	14 days
		2		40 ml	POP	8270		Cool, 4°C
Ambient Air	Air	6	Filter in Plastic Bag		Particles PCB	Gravimetric 8080	Cool, 4°C	7 days before and 40 days after extraction

* Source: EPA SW-846

000661 - C00661

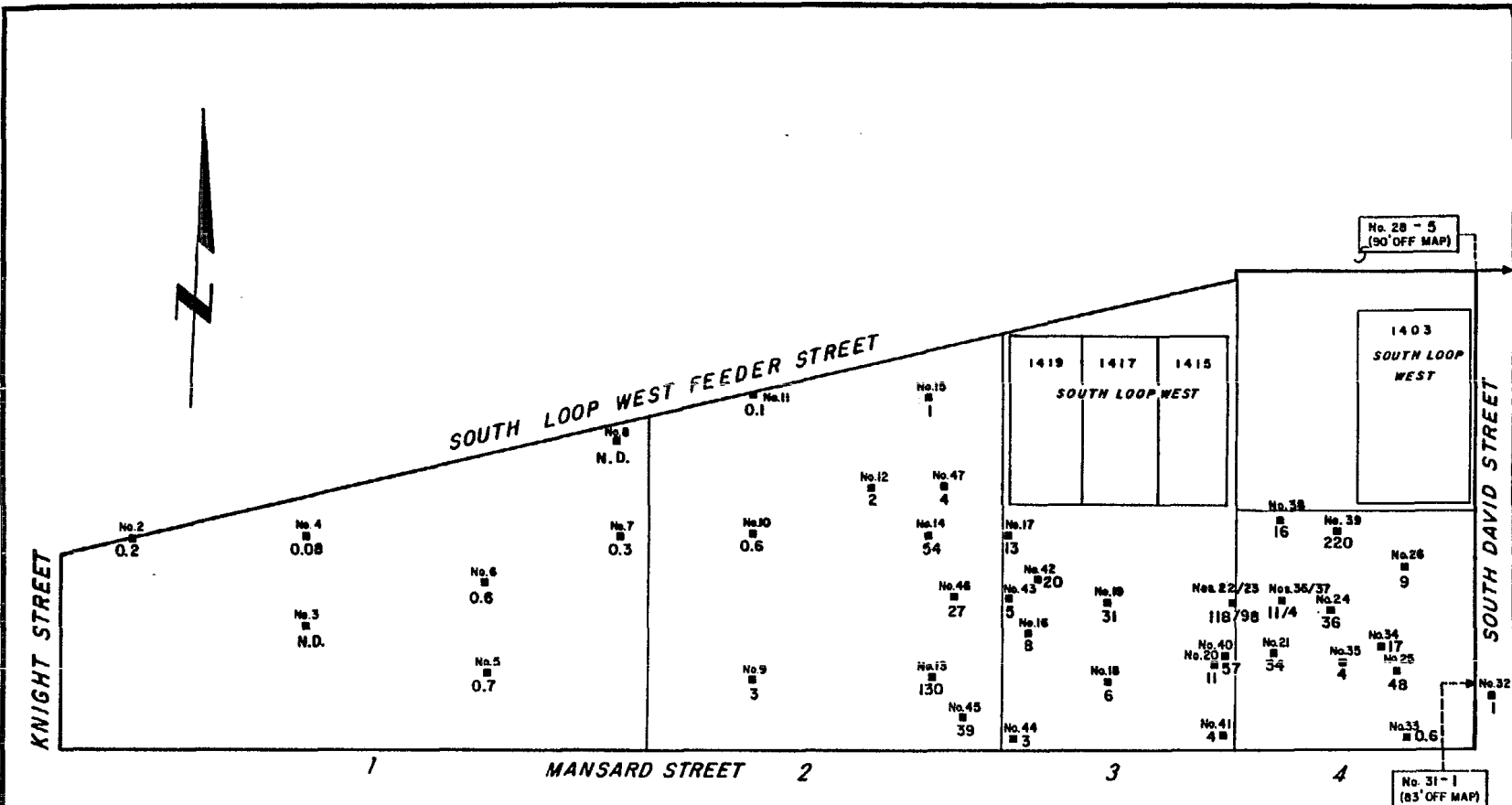

LEGEND

No. 7 SAMPLE NUMBER
 ■ SAMPLE LOCATION
 0.3 SAMPLE VALUE
 N.D. NONE DETECTED

FIGURE I-2
PCB VALUES IN
SURFACE SOIL SAMPLES
(PPM)



RADIAN
CORPORATION

FOR THE PURPOSES OF PRESENTATION,
 ALL VALUES HAVE BEEN ROUNDED OFF.

000662

concentrations from 1 to 5 ppm PCBs and one sediment sample next to Area 3 exhibited a concentration of 47 ppm PCBs. Only Areas 2, 3, and 4 exhibit PCB concentrations greater than 25 ppm in soil, a limit based on EPA policy discussed in the RI and derived from the Toxic Substances Control Act (TSCA) cleanup recommendations.

Distributions of the TCE values for surface soils are shown in Figure 1-3. Concentrations range from 0.02 to 2 ppm. Areas 3 and 4 exhibit slightly higher TCE concentrations due to their proximity to the punctured barrels. Because of its volatility, TCE is found only in low concentrations in surface soil samples.

A Priority Organic Pollutants (POP) analysis on surface soil samples revealed the presence of methylene chloride, acetone, and chrysene in addition to TCE. The presence of methylene chloride and acetone may be explained due to their association with field cleaning processes and use as laboratory extraction agents.

Shallow soil borings* were drilled to a depth of 4 feet at various locations on site yielding two samples from each boring, a composite from the upper 2 feet and one from the lower 2 feet section, to be analyzed for PCBs and TCE. Consistent with surface soil data, PCBs were not detected in Areas 1 and 5. Area 2 exhibits a wide range of PCB values from 0.05 ppm to 220 ppm, and for the most part, the concentrations appear to decrease with depth. PCB values also tend to decrease with depth in Area 3. Concentrations in Area 3 range from a low of none detected to a high of 0.35 ppm. PCB concentrations in Area 4 range from 0.5 ppm to 25 ppm and decrease significantly with depth. These values are shown in Figure 1-4. While not anticipated, Area 2 shows higher PCB concentrations which could be due to transport via surface water or the occurrence of more industrial activities taking place in Area 2 than in Area 3.

*The laboratory analysis on the sample obtained from the 2 to 4 foot depth for shallow borehole No. 12 has been discarded because the laboratory holding time was exceeded. The QA/QC report provides more detail on this particular sample.

00663

6-1

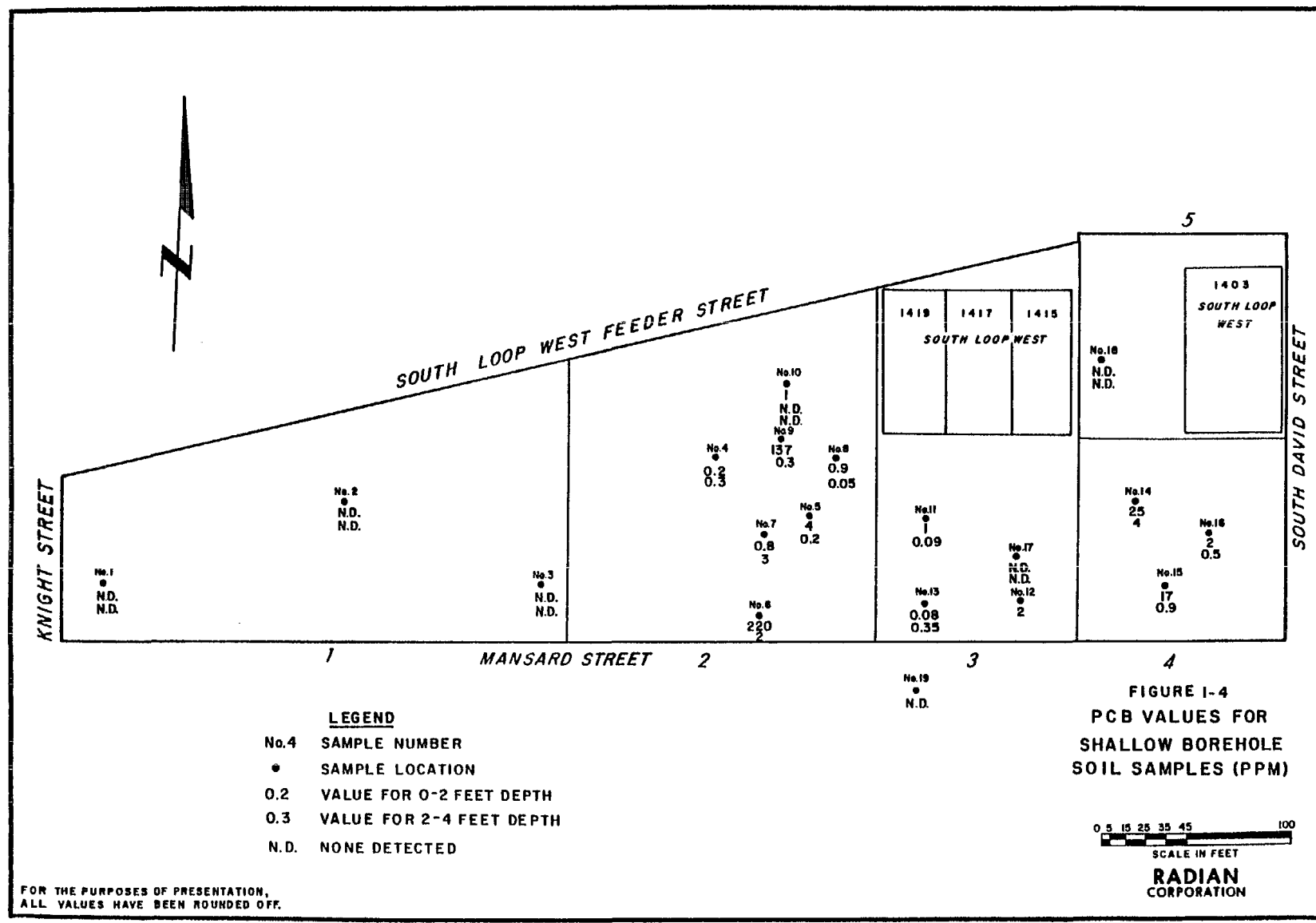

FIGURE I-4
PCB VALUES FOR
SHALLOW BOREHOLE
SOIL SAMPLES (PPM)

0 5 15 25 35 45 100
SCALE IN FEET

RADIANT CORPORATION

000665

Shallow boreholes were also augered to obtain samples for TCE evaluation. Area 1 boreholes yielded 0.005 ppm TCE in the upper 2 feet and 0.006 ppm TCE in the 2 to 4 foot depth interval for one hole and none detected for two other boreholes. Concentrations in Area 2 ranged from 0.008 ppm to 150 ppm TCE with no definite trends in distribution. The range of TCE values in Area 3 was 0.09 ppm to 3 ppm. Area 4 showed 0.02 ppm TCE for both samples taken at one borehole. In general, little TCE exists in the upper 4 feet of soil at the site except for a localized section in Area 2. Figure 1-5 shows the TCE concentrations in the shallow boreholes.

Four shallow borehole samples composited over the upper 4 feet of depth were analyzed for POP. Figure 1-6 shows the locations of these boreholes. As shown in Table 1-2, the POP analysis detected 7 different compounds:

- TCE ranging from 0.0036 to 0.0082 ppm,
- Methylene chloride ranging from 0.0036 to 0.0082 ppm,
- Trans-1, 2-dichloroethene ranging from 0.0031 to 8.5 ppm,
- 2-butanone ranging from 7.4 to 15 ppm,
- Benzene at 0.91 ppm,
- Tetrachloroethene at 0.5 ppm, and
- Acetone ranging from 0.11 to 6 ppm.

As expected, shallow boreholes B-5 and B-7 which are located in Area 2 show significantly higher POP concentrations than either B-3 located in Area 1 or B-15 located in Area 4. The POPs are generally used as industrial solvents and likely have been used at the ITS site. The POP analysis confirms the presence of TCE. However, POPs other than TCE occur in limited quantities at the site. The presence of acetone can be explained by its use during field cleaning procedures. Methylene chloride and acetone are generally associated with laboratory extraction procedures.

Because dioxins are an incomplete combustion product from the burning of PCBs and may be found in conjunction with PCEs in soil contamination scenarios, four soil samples were submitted for dioxin analysis. Dioxins were not detected in any of these samples.

TABLE 1-2
 PRIORITY ORGANIC POLLUTANTS ANALYSIS

199003

Shallow Borehole	Contaminant
B-3	0.0031 ppm TCE 0.0082 ppm methylene chloride 0.0015 ppm trans-1, 2-dichloroethene
B-5	37 ppm TCE 0.63 ppm trans-1, 2-dichloroethene 7.4 ppm 2-butanone 0.91 ppm benzene 0.5 ppm tetrachloroethene
B-7	57 ppm TCE 6 ppm acetone 8.5 trans-1, 2-dichloroethene *15 ppm 2-butanone
B-15	0.11 ppm acetone 0.0036 ppm methylene chloride 0.0036 ppm trans-1, 2-dichloroethene

* Also detected in laboratory reagent blank.

I-12

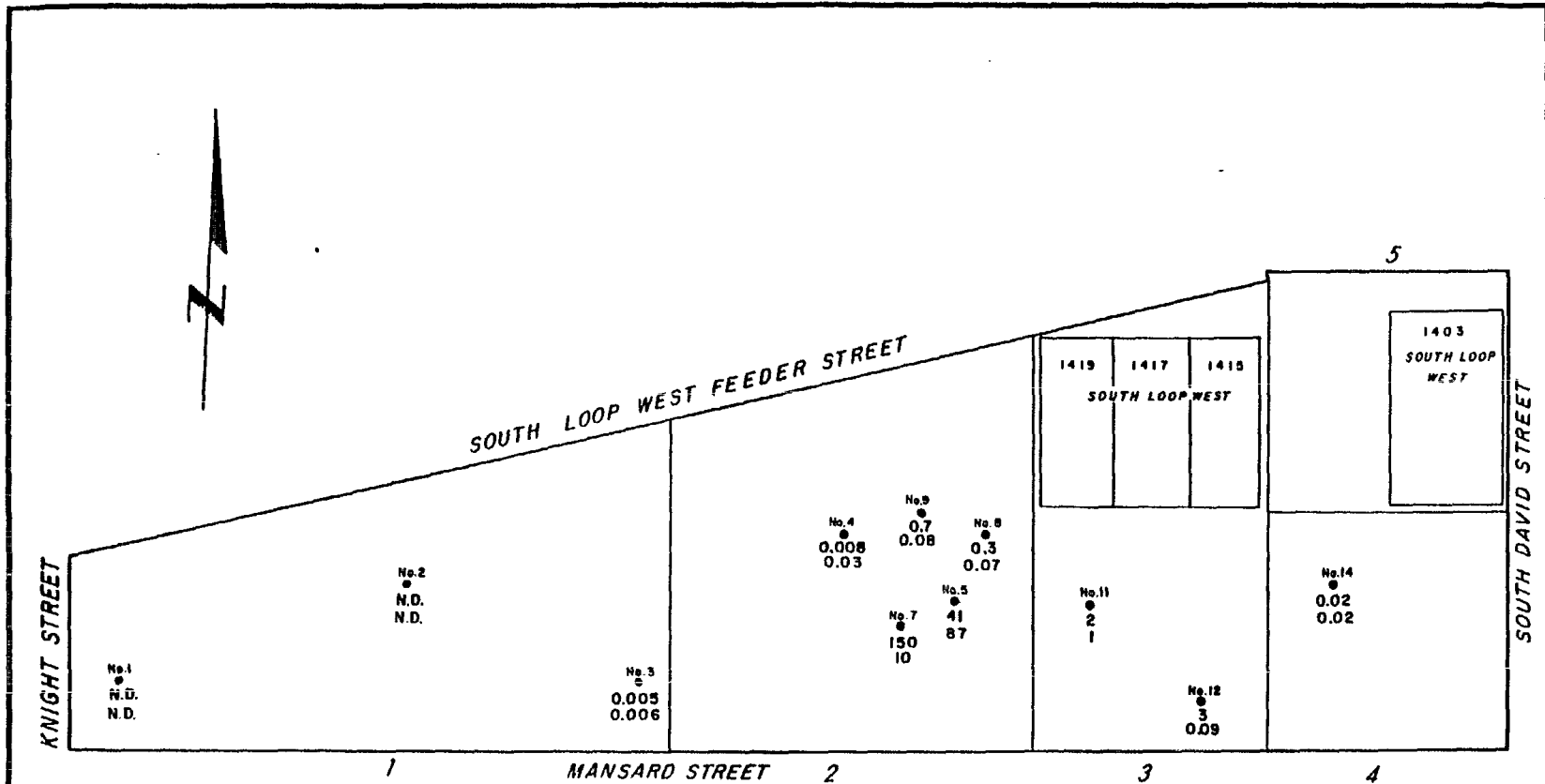

LEGEND

- No.11 SAMPLE NUMBER
- SAMPLE LOCATION
- 2 VALUE FOR 0-2 FEET DEPTH
- 1 VALUE FOR 2-4 FEET DEPTH
- N.D. NONE DETECTED

FIGURE I-5
TCE VALUES IN
SHALLOW BOREHOLE
SOIL SAMPLES (PPM)

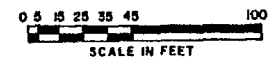

RADIAN
CORPORATION

FOR THE PURPOSES OF PRESENTATION,
ALL VALUES HAVE BEEN ROUNDED OFF.

--000668

I-1-1

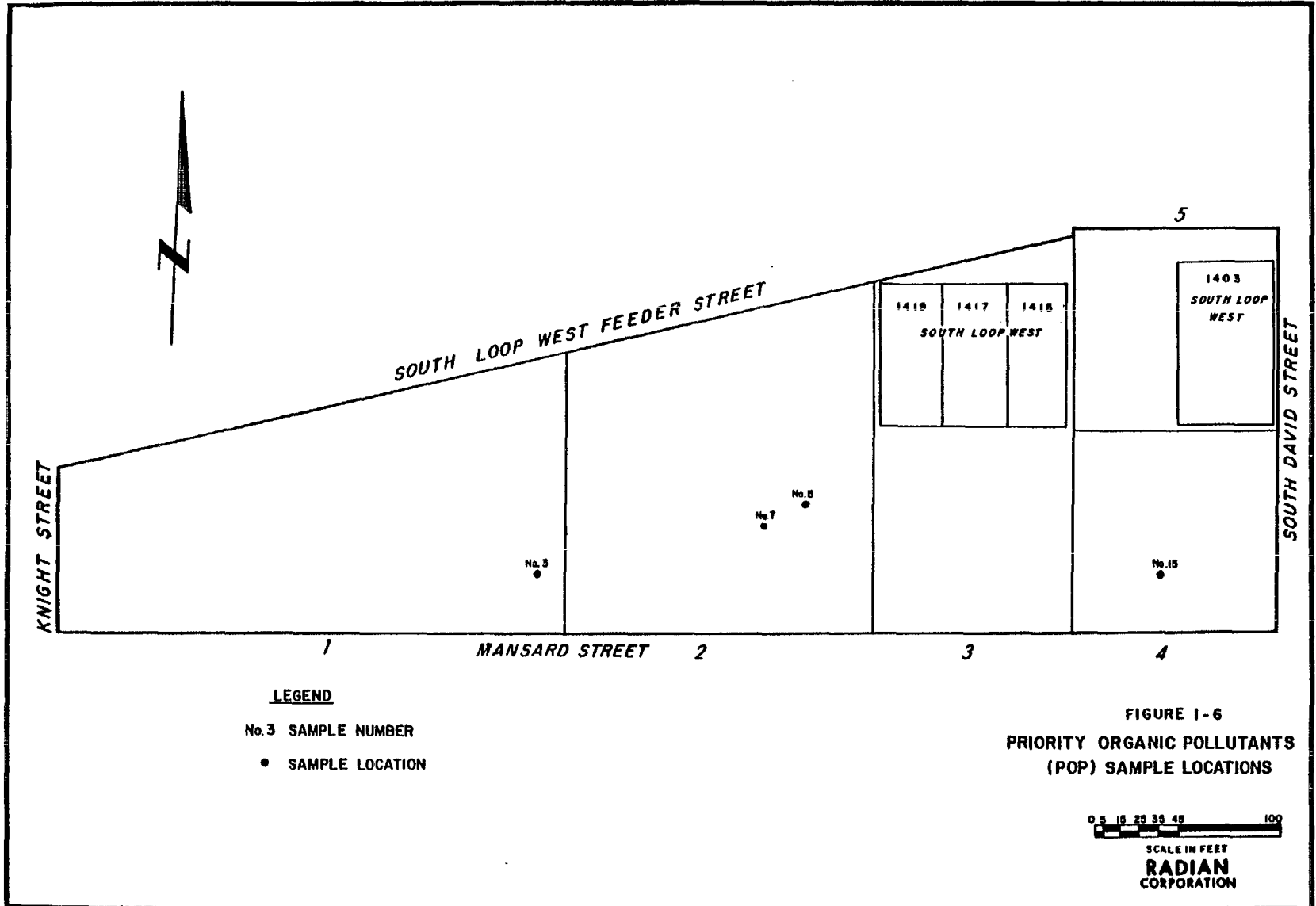

000669

029000 - 000670

Surface water and sediment samples were also collected and analyzed for PCBs. Out of seven water samples collected from puddles on-site and the ditches along Knight and Mansard Streets, PCBs were detected in one sample on-site at a concentration of 0.0011 ppm. Six sediment samples were collected from ditches on both sides of Mansard Street, yielding values ranging from 0.17 ppm to 47 ppm. Six of the seven samples showed concentrations less than or equal to 1 ppm.

In conclusion, TCE and PCB surface and shallow subsurface contamination is highly localized and confined to the empty lots behind the 1403, 1415, 1417, and 1419 South Loop West addresses and in areas west of these addresses. Significant PCB concentrations (greater than 25 ppm) are limited to the upper two feet of soil. TCE contamination up to 150 ppm occurs between 0 and 4 feet of depth. This description delineates the extent of TCE and PCB contamination in the surface and shallow subsurface soils at the ITS site.

As described in the RI, the TCE cleanup criteria is set at 161 ppm in soil.

1.3 OBJECTIVES OF REMEDIAL ACTIONS

The nature and extent of contamination at the ITS site have been delineated by the RI. Data presented in Figure 1-4 shows PCB contamination greater than 25 ppm to exist only in the upper 2 feet of depth. Figure 1-5 shows TCE contamination greater than the 161 ppm cleanup level, not to be exceeded in the surface and shallow subsurface soils, (i.e., soils at a depth of less than 2 feet). Therefore, this FS is concerned with only the surface and shallow subsurface contamination of soils with TCE and PCBs and will address cleanup alternatives directed toward the upper 2 feet of soil on the site. The areal extent of surface soil remediation is shown in Figure 1-7. An additional FS to be conducted separately will consider alternatives to remediate groundwater and deeper subsurface contamination of both PCBs and TCE.

Applicable or Relevant and Appropriate Requirements (ARARs), as described in the RI, will be used to determine the effectiveness of a remedial alternative to achieve environmental and public health objectives. The Superfund Amendments and Reauthorization Act (SARA) of 1986 require that remedial alternatives attain the ARARs of all pertinent environmental statutes including federal regulations and the more stringent state requirements.

PCBs and TCE are the principal contaminants at the site, and both are classified by the EPA as potential carcinogens (Federal Register, November 13, 1985). Possible exposure pathways at the site include: vertical migration of contamination via rainfall infiltration to the underlying aquifer; horizontal migration of contaminants via rainfall run-off to surface water bodies; and wind erosion of soils causing contaminants to become airborne. These contaminant pathways can result in the ingestion, inhalation, and skin absorption of contaminants, thereby impacting public health and the environment.

With these pathways in mind, various technologies are evaluated and combined to form complete alternatives to remediate the negative public health or environmental impacts that may exist at the ITS site. The objective of the remedial activity is to protect public health. To meet this goal, the following maximum allowable soil concentration levels have been established in the RI:

- 25 ppm PCBs and
- 161 ppm TCE.

The PCBs cleanup criteria is driven by inhalation exposure and has been promulgated by the TSCA. The TCE criteria was determined by factoring in inhalation and ingestion considerations and has been calculated to be 161 ppm. This calculation is presented in the RI.

To meet these criteria, the proposed surface and shallow subsurface remediation area is shown in Figure 1-7. The remediation area consists of approximately 0.75 acres of soils contaminated with PCBs to a depth of 2 feet

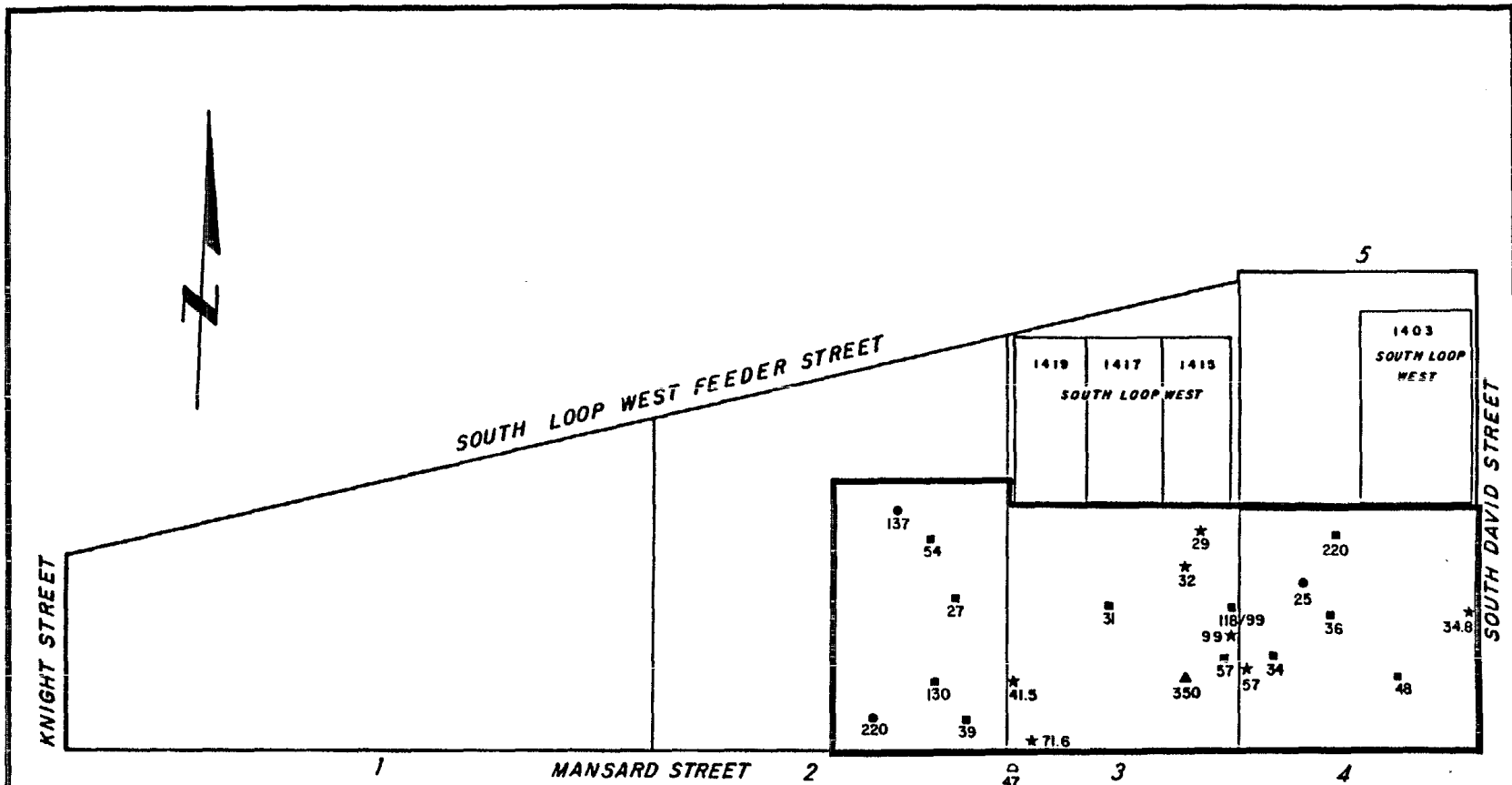

LEGEND

- SURFACE SOIL LOCATION
- SHALLOW BORING LOCATION
- ▲ DEEP BORING/MONITOR WELL LOCATION
- ★ SURFACE SOIL LOCATION (TWC AND OTHERS)
- SEDIMENT LOCATION
- 32 SAMPLE VALUE

FOR THE PURPOSES OF PRESENTATION,
ALL VALUES HAVE BEEN ROUNDED OFF

FIGURE I-7

AREAL EXTENT OF SURFACE SOIL
REMEDIATION USING 25 PPM
PCB CUT - OFF LIMIT



RADIAN
CORPORATION

100-100-000672

for a total volume of approximately 2500 cubic yards. Note that this volume and area are rounded up slightly from those values reported in the RI to account for hot spots. "Hot Spot" sampling will occur during the remediation to ensure the cleanup criteria are met. For example, the 47 ppm PCB sample located in the ditch along Mansard Street will be confirmed and delineated, so that this area can be remediated with the rest of the site. The TSCA regulates PCBs treatment and disposal methods used to meet cleanup criteria.

011113 --C00673

SECTION 2
PRELIMINARY SCREENING OF TECHNOLOGIES

00000000-000674

As noted in Section 1.3, Objectives of Remedial Actions, this part of the FS will deal only with remediation of the upper two feet of contaminated soils or surface and shallow subsurface soils, which are primarily contaminated with PCBs. Meeting the PCB criterion during remediation also meets the TCE cleanup criterion; therefore, the high PCB concentrations will be used as the indicator for remedial strategies. However, the TCE should still be considered because its presence may impact the PCB remediation. Remediation of deep subsurface soils and groundwater contamination will be considered in a subsequent report. This chapter presents a description of available response actions and technologies and screens them for applicability to the ITS site.

In developing the candidate list of remedial technologies, the first step was to identify the broad categories of response which may be carried out to remediate PCB contaminated shallow soils. Once the response categories were finalized, appropriate technologies within the context of each response were identified.

Subsequently, the technologies were screened according to the following criteria:

- Implementability,
- Time required for implementation,
- Proven effectiveness, and
- Applicability to site and waste.

First, a technology was evaluated for its physical implementability. Next, the length of time required to implement a technology was considered. For most technologies, an implementation time can be calculated rather accurately; however, some technologies such as biological methods may require a time frame on the order of years or decades to reduce contaminant concentrations to an

adequate level, and the time for remediation cannot be determined without a treatability study. Third, the technologies were screened for proven effectiveness. A successful field scale trial of a particular technology renders that technology as "proven effective". Otherwise, a technology is listed as not proven effective. Fourth, the determination of the applicability of the technology to site refers to site conditions and the contaminant properties. For example, many of the technologies may meet the other criteria, but do not destroy or permanently immobilize PCBs and are therefore not preferable for the site or the waste. Finally, a determination of further consideration as a remediation technique for the ITS site was made by using these screening criteria.

The ability of the technology to remediate the contaminants to meet relevant public health or environmental standards, the cost of implementing the technology, and the ability of the technology to achieve permanent treatment or destruction of the wastes were not used as criteria for the elimination of a technology at this stage of the screening process but will be discussed in a later section of the feasibility study.

2.1 GENERAL RESPONSE ACTIONS

The EPA Guidance Document (1985) lists general response actions which may be carried out to remediate the shallow soil contamination at the ITS site. Based on consideration of site conditions and the principal nature of the contaminants (PCBs), a list of generalized response actions has been generated and is shown in Table 2-1. Also, included in this table is a listing of technologies which can be categorized within each general response.

The following sections provide additional details on the technologies identified in Table 2-1 and review them for applicability to the ITS site. For ease in presentation, subsequent discussions will be based on technologies rather than general response actions.

TABLE 2-1. LIST OF GENERAL RESPONSE ACTIONS

General Response Actions	Technology Types
No Action	-
Containment	Capping, dust control, revegetation.
Diversion	Gradings, dikes, berms, ditches to control run-off during remediation.
Excavation and Removal	Partial or complete excavation of contaminated soil and transport to another on-site location, or removal to an off-site location.
On-Site Treatment	Treatment of excavation of contaminated soil and transport to another on-site location, or removal to an off-site location.
In Situ Treatment	In place treatment of contaminated soil; treatment can be biodegradation, landfarming, soil flushing, or aeration, and in situ glassification.
On-Site Disposal	Disposal of excavated material at a location within the ITS site; disposal methods can be landfarming or landfilling.
Off-Site Treatment/Disposal	Disposal of excavated material at an approved off-site facility; the disposal facility can be a landfill, a land treatment facility or incinerator.

Source: U.S. EPA, 1985.

92900--00676

TABLE 2-2. SCREENING OF REMEDIAL TECHNOLOGIES FOR SURFACE SOILS

REMEDIAL TECHNOLOGIES	SCREENING CRITERIA			APPLICABLE TO SITE AND WASTE	WARRANTS FURTHER CONSIDERATION	COMMENTS
	Implementable	Time Required Acceptable	Proven Effective			
● Capping						
- Synthetic membranes	Yes	Yes	Yes	Yes	Yes	Proven local vendors; material compatibility not a problem; puncture and deterioration should be considered.
- Clay	Yes	Yes	Yes	Yes	Yes	May require top soil and drainage layer; cracking and erosion may be problems.
- Asphalt	Yes	Yes	Yes	Yes	Yes	May introduce organics; cracking may be a problem.
- Multimedia cap	Yes	Yes	Yes	Yes	Yes	May be needed with synthetic or clay.
- Concrete	Yes	Yes	Yes	Yes	Yes	May change pH in near surface; cracking may be a problem.
- Chemical sealants/stabilizers	Yes	Yes	No	Yes	No	Not proven in long-term.
● Dust Control Measures						
- Polymers	Yes	Yes	Yes	Yes	Yes	To be considered further as a support technology only.
- Water	Yes	Yes	Yes	Yes	Yes	To be considered further as a support technology only.
- Scarification	Yes	Yes	No	No	No	Not applicable.
- Tracking	Yes	Yes	No	No	No	Not applicable.
- Contour furrowing	Yes	Yes	No	No	No	Not applicable.
● Revegetation	Yes	Yes	Yes	Yes	Yes	To be considered further as a support technology only.
● Diversion and Collection Systems (Rainwater)						
- Grading	Yes	Yes	Yes	Yes	Yes	To be considered further as a support technology only.
- Dikes and berms	Yes	Yes	Yes	Yes	Yes	To be considered further as a support technology only.
- Ditches and trenches	Yes	Yes	Yes	No	No	Not applicable.
- Terraces, benches, chutes, downpipes, seepage basins, levees	Yes	Yes	Yes	No	No	Not applicable.
- Retention basins	Yes	Yes	Yes	Yes	Yes	To be considered further as a support technology only.
- Addition of freeboard	Yes	Yes	Yes	No	No	Not applicable.
- Floodwalls	Yes	Yes	Yes	No	No	Not applicable.

2-5

000678

TABLE 2-2. SCREENING OF REMEDIAL TECHNOLOGIES FOR SURFACE SOILS (Continued)

REMEDIAL TECHNOLOGIES	SCREENING CRITERIA			APPLICABLE TO SITE AND WASTE	WARRANTS FURTHER CONSIDERATION	COMMENTS
	Implementable	Time Required Acceptable	Proven Effective			
● Treatment or Management of Liquid Waste Streams (Rainwater)						To be considered further as a support technology only.
- Retention, testing, and Discharge	Yes	Yes	Yes	Yes	Yes	NPDES permit requirements must be met.
- Biological treatment	Yes	Yes	Yes	Yes	Yes	NPDES permit requirements must be met.
- Chemical treatment	Yes	Yes	Yes	No	No	Concentration too low.
- Physical treatment	Yes	Yes	Yes	Yes	Yes	NPDES permit requirements must be met.
- Discharge to a POTW	Yes	Yes	Yes	Yes	Yes	City permit requirements must be met.
- Deep well injection	Yes	Yes	Yes	Yes	Yes	
● Excavation and Removal						
- Backhoe	Yes	Yes	Yes	Yes	Yes	Probably not the most efficient method.
- Cranes and attachments	Yes	Yes	Yes	Yes	Yes	Likely method.
- Front-end loaders	Yes	Yes	Yes	Yes	Yes	Likely method.
- Scrapers	Yes	Yes	Yes	Yes	Yes	Probably not the most efficient method.
- Pumps	Yes	Yes	Yes	Yes	Yes	Support technology only.
- Industrial vacuums	No	No	No	No	No	Not applicable for dry soil.
- Drum grapplers, fork-lifts	Yes	Yes	Yes	Yes	Yes	Only necessary here if small quantities are drummed.
● Solidification, stabilization, or fixation						
- Thermoplastic, organic polymer	Yes	Yes	Yes	No	No	Not generally used with soils contaminated with PCBs.
- Stabilization (cement, lime, fly ash, etc.)	Yes	Yes	Yes	Yes	Yes	TCLP test may be required
● Land Disposal/ Storage (On-Site and Off-Site)						
- Landfills	Yes	Yes	Yes	Yes	Yes	PCB and TCE have different requirements.
- Surface impoundments	No	Yes	No	Yes	Yes	To be considered further as a support technology only.
- Land application	Yes	Yes	No	No	No	Only for liquids.
- Waste piles	Yes	Yes	No	Yes	Yes	To be considered further as a support technology only.
- Deep well injection	Yes	Yes	Yes	Yes	Yes	
- Temporary storage	Yes	Yes	Yes	Yes	Yes	

2-6

00007 - 000679

TABLE 2-2. SCREENING OF REMEDIAL TECHNOLOGIES FOR SURFACE SOILS (Continued)

REMEDIAL TECHNOLOGIES	SCREENING CRITERIA			APPLICABLE TO SITE AND WASTE	WARRANTS FURTHER CONSIDERATION	COMMENTS
	Implementable	Time Required Acceptable	Proven Effective			
● Incineration (On-site and Off-site)						
- Liquid Injection	Yes	Yes	Yes	Yes	Yes	To be considered further as a support technology only.
- Fluidized Bed	Yes	Yes	Yes	Yes	Yes	Availability is limited.
- Rotary Kiln	Yes	Yes	Yes	Yes	Yes	Transportable and fixed available.
- Electric Infrared	Yes	Yes	Yes	Yes	Yes	Transportable only.
- Electromelt	No	Yes	Yes	Yes	No	Not currently commercially available.
- Plasma Arc	No	Yes	Yes	Yes	No	Not currently commercially available.
- Molten salt	No	Yes	Yes	Yes	No	Not currently commercially available.
● Non-Thermal Treatment (On-Site and Off-Site)						
- Wet Air Oxidation	Yes	Yes	No	Yes	Yes	Not a proven technology; innovative.
- Activated Sludge Methods	Yes	Yes	No	Yes	Yes	Biological slurry method; innovative.
- Other Biological Methods	Yes	Yes	No	Yes	Yes	Landfarm biological method; innovative.
- Chemical Treatment	Yes	Yes	No	Yes	Yes	Reactor vessel chemical treatment; innovative.
● In Situ Treatment						
- Hydrolysis, oxidation, and reduction	No	Yes	Yes	No	No	Only applicable to aqueous material.
- Soil aeration	Yes	Yes	Yes	No	No	Most applicable to TCE; air pollution is a concern; innovative; support for other methods.
- Solvent flushing/soil washing	Yes	Yes	No	No	Yes	Innovative.
- Neutralization	Yes	Yes	Yes	No	No	pH is not a problem.
- Polymerization	No	Yes	Yes	No	No	Does not apply to PCB or TCE in soil.
- Sulfide precipitation	No	Yes	Yes	No	No	Does not apply to PCB or TCE in soil.
- Biodegradation	Yes	?	No	Yes	Yes	Decay rate variable; innovative, but unproven for PCBs.
- Chemical Dechlorination	Yes	Yes	No	Yes	Yes	Innovative; byproducts include polyhydroxylated biphenyls and hydroxy benzenes.
- Glassification	Yes	Yes	No	Yes	Yes	In-situ possible; innovative.

2-7

000680

As shown on Table 2-2 a variety of cap materials can be used; all are applicable to this site. Also, they are all implementable and can be constructed in a reasonable time period. They are proven effective in controlling air pollution (primarily dust at this site) and in controlling contaminated run-off by preventing contact with contaminated soil. Multimedia caps may be required to protect synthetic membranes from puncture and photochemical degradation or to provide topsoil (for vegetation) and underdrainage for clay caps. Concrete and asphalt are possibilities for capping; however, concrete may crack, and asphalt will introduce new organics to the site and care is required to not confuse the sources. Chemical sealants are not considered further because they are not proven to be effective, long-term solutions. By elevating the overall grade, caps may interfere with existing commercial activity at the site.

00001-00681

2.2.3 Dust Control Measures

The dust control measures, such as the application of water or polymers to the soil as shown on Table 2-2, may be useful at the ITS site as part of support alternatives designed to accomplish containment, on-site treatment or disposal, or off-site treatment or disposal. Dust control procedures are temporary measures which theoretically reduce the airborne inhalation pathway caused during remediation by heavy equipment disturbing the soil. The dust control procedures work by binding with or weighing down the soil particles and preventing their becoming airborne.

Polymers or water used in controlled amounts may be useful during the movement of heavy equipment, which may cause contaminated dust to become airborne. However, application of polymers or water is only a temporary measure, and once the water has evaporated or the equipment has excavated below the soil layer upon which polymers have been sprayed, the particles once again show propensity to become airborne unless further application of water or polymers occurs. Scarification, tracking, and contour furrowing are all long-term dust control measures which are not completely effective and are not applicable at this site.

Since airborne contaminants at the ITS site have been determined to present a health risk at the site, remediation technologies which remove or destroy the surface and shallow subsurface PCB contamination will be considered as a means of reducing the inhalation pathway. Dust control measures will only be considered further as a supportive measure of implementing one of the alternatives.

2.2.4 Revegetation

Revegetation may be a part of several alternatives, but it is not likely to be an alternative by itself. Revegetation helps prevent soil erosion caused by wind and water by providing a protective vegetative cover with roots to bind soil particles. While both air and surface water pathways of exposure have been determined to present a health risk to nearby populations, remedial technologies which address solely those pathways are not as effective in remediating these pathways as technologies which address the entire volume of contaminated soils. revegetation works well as a supportive measure with the more permanent alternatives such as capping and drainage control structures and as an aesthetic improvement after waste remediation. When used with a permanent alternative, the revegetation aspect will require perpetual maintenance including insect control, fertilizer application, irrigation, and dead plant removal and replacement.

2.2.5 Diversion and Collection Systems (Rainwater)

Diversion and collection systems are useful in controlling the surface water pathway. Structures applicable to this site for controlling surface water run-off are grading, dikes, and berms. Diversion denotes the use of these structures to divert off-site run-off from entering the ITS site. The same structures can also be used to collect the run-off generated on-site so that it may be treated, if required. Typically, a site will be surrounded on all sides by a berm (or dike) of sufficient height to form a retention basin such that off-site run-on cannot enter the site and on-site run-off is then collected inside the berm.

000002 - 00682
89000

89000

Because surface water pathways have been shown to not present a significant health risk at the site, diversion and collection structures will only be further considered as supportive measures of a permanent soil remedial action. Collection and diversion structures are a prerequisite to the treatment of liquid waste streams from rainwater.

The other diversion/collection structures listed in Table 2-2 are more useful at sites containing much larger volumes of surface water run-off than the ITS site.

2.2.6 Treatment of Liquid Waste Streams (Rainwater)

Rainwater that falls directly on the site may be contained by using collection structures described in the previous section and then treated. Run-off from off-site will be diverted to the extent practicable. For rainwater which comes in contact with contaminated soils the following general technologies may be used in conjunction with retention:

- Testing and discharge to a ditch or Publicly Owned Treatment Works (POTW),
- Testing and biological, chemical, or physical treatment; or
- Deep well injection or other form of hazardous waste disposal.

PCBs are not very soluble in water and the concentrations of TCE in the near surface soils are low. Therefore, an alternative technology addressing this issue is retention of the run-off in a lined basin until testing can confirm that contaminants are not present, or present in acceptably low concentrations, and subsequent discharge to existing drainage structures.

Should the rainwater require treatment, biological treatment is feasible and appropriate on-site or at a POTW. However, PCBs degrade slowly and the concentration, volume, and required retention time (based on decay rate) will determine the feasibility of biological treatment. If on-site (but

not in situ) biological processes are selected for treating contaminated groundwater, then the obvious choice for treating rainwater would also be on-site biological treatment. The two waste streams, rainwater and groundwater, could be treated together in one reactor or one series of reactor vessels.

Chemical treatment of PCBs in water theoretically may include oxidation, hydrolysis, and a variety of unproven high technology options. However, the concentrations of PCBs in the rainwater collected on the ITS site will likely be too low to make any of these technologies practicable.

Physical treatment may include activated carbon, Kleensorb, distillation, stripping, and a variety of solids removal technologies such as settling. If PCBs in the rainwater are primarily associated with solids, then filtration, flocculation, settling, and sedimentation will be considered. If the PCBs are dissolved, activated carbon and Kleensorb may be more cost-effective.

All of the rainwater treatment technologies discussed may be implemented before discharge, which will mean meeting the effluent quality requirements of a National Pollution Discharge Elimination System (NPDES) permit, or as a pretreatment method prior to discharge to a city sewer and, subsequently, a POTW. The impact of this waste stream on a Houston POTW would be insignificant. Treatment efficiency will require investigation, as will the regulatory aspects of wastes from a Superfund site entering a POTW.

2.2.7 Excavation and Removal

Excavation and removal (off-site or elsewhere on-site) are clearly applicable to this site since the extent of shallow subsurface contamination is limited to the upper two feet of soil over approximately 0.75 acre of the site. This technology will be required to implement a variety of on-site or off-site destruction or storage technologies. Soils containing greater than 50 ppm but less than 500 ppm PCBs can be landfilled at a TSCA approved landfill. All of

the solids loading and transport technologies are applicable to the site and the waste. As listed on Table 2-2, these include backhoe, cranes with attachments (clam shell, drag line), front-end loaders, and scrapers. Liquid moving techniques such as pumps and industrial vacuums (vacuum trucks, "super suckers") are only applicable to run-off and will be evaluated as a part of complete treatment alternatives. Drum grapplers and forklifts may be useful if small volume "hot spots" are drummed to segregate the wastes from other contaminated material.

58900

2.2.8 Solidification, Stabilization or Fixation

There are a variety of innovative techniques designed to prevent PCB contaminants from leaching from waste material. These include thermoplastic encapsulation; organic polymers; and solidification with cement, lime, fly ash, etc. Thermoplastic encapsulation and organic polymers are not typically used with PCBs and are not proven for this purpose.

Solidification binds the waste materials mechanically with cement, lime or fly ash into a solid that does not readily release the contaminants upon exposure to air or water. This technique is implemented by mixing the wastes with the solidification agents and placing the resulting solid waste into a landfill. Using cement as the solidifier consolidates the wastes into a rock-like mass. Lime-based solidification agents result in a more porous product. Because cement-working is a well known technology and cement is not very sensitive to waste variability, the use of cement solidification is a technology worthy of further consideration.

2.2.9 Land Disposal/Storage (On-Site and Off-Site)

Land disposal requirements differ for TCE and PCBs. TCE is regulated under the Resource Conservation and Recovery Act (RCRA) while PCBs are governed by the TSCA. However, PCB contamination is of primary concern in the upper two feet of soil at the ITS site. Waste containing 50 to 500 ppm of PCBs may be

2.2.10 Incineration

Various provisions of the RCRA and the TSCA govern the disposal of PCBs. The current EPA guidelines for the disposal of PCBs are:

- Materials containing less than 50 ppm PCBs are not regulated as a PCB waste, and
- Materials containing greater than 500 ppm PCBs must be incinerated.

Section 6(e) of TSCA requires the EPA to regulate the manufacture, processing, distribution in commerce, use, disposal, and labeling of materials containing PCBs. The Federal Register, 40 CFR 761.70, is a compilation of all EPA guidelines applicable to the incineration of PCBs, and it specifies that approval of an EPA Regional Administrator or the Assistant Administrator for Pesticides and Toxic Substances must be obtained before incineration commences.

Combustion criteria for both solid and liquid PCBs are as follows. The rate and quantity of PCBs fed to the incinerator shall be measured and recorded at intervals of no longer than 15 minutes. Temperatures of the incineration process shall be continuously monitored and recorded. Stack emission monitoring shall occur when an incinerator is first used for PCB disposal. Monitoring shall be conducted for at least:

- Oxygen (O₂),
- Carbon monoxide (CO),
- Carbon dioxide (CO₂),
- Nitrogen oxides (NO_x),
- Hydrochloric acid (HCl),
- Total chlorinated organic content (RCl),
- PCBs, and
- Total particulates.

However, monitoring and recording of combustion products and incineration operations shall occur for at least the following parameters during PCB burns:

- Continuous O₂ and CO monitoring, and
- Frequent interval CO₂ monitoring.

Furthermore, the flow of PCBs to the incinerator shall stop if failure of either the monitoring operations or the rate and quantity measuring and recording equipment occurs. Finally, the Federal Register states that water scrubbers are required to remove HCl during PCB incineration.

Commercial PCB incineration facilities tend to have similar operating capacities.* Sludge and liquids from scrubbing processes are usually treated and discharged or disposed by deep well injection. The incinerator ash is often landfilled at a hazardous waste facility or it may be reclassified and backfilled.

Specific requirements that incinerators of PCBs must meet are:

- For liquid PCBs, either a 2 second detention time and 3% excess oxygen at 2192^oF (1200^oC) or 1.5 second detention time and 2% excess oxygen at 2912^oF (1600^oC);
- Combustion efficiency of at least 99.9% (49 CFR 761.70); and
- PCB emissions less than 1 mg/kg PCBs destroyed (or 1 ppm PCBs in emissions) with a 99.9999% destruction removal efficiency (DRE).

* Typical primary combustion chambers have the capability to handle containerized wastes in 85-gallon drums or smaller, bulk solid wastes, pumpable liquid wastes, slurries, and sludges while secondary combustion chambers can handle pumpable liquid or slurry wastes.

889000

689000

Possible incineration technologies include:

- Liquid Injection,
- Fluidized Bed,
- Circulating Bed,
- Rotary Kiln,
- Electric Infrared,
- Electromelt,
- Plasma Arc, and
- Molten Salt.

The first five technologies are currently being offered by contractors who perform on-site and/or off-site incineration of wastes. The last three technologies are dropped from further evaluation because they are not currently commercially available. Liquid injection, best for liquid PCB wastes, is typically conducted in a secondary combustion chamber of a rotary kiln incineration by direct injection port for fluid waste incineration. The fluidized bed incinerator allows for more efficient oxidation of the wastes by increasing the heat distribution through fluidizing the solids to be incinerated. Fluidized bed incinerators operate at similar destruction efficiencies but at lower temperatures than rotary kilns. Circulating beds operate at higher velocities than the fluidized bed to obtain a more compact incineration unit. Rotary kilns are the primary incineration technology available for the treatment of wastes. Solid wastes are fed into one end of a rotating kiln and incinerated. Liquid wastes are injected into the secondary burner, or liquid injection incinerator. The final type of incinerator is the electric infrared system in which the solid wastes are fed onto a moving belt into the incinerator where they pass under glow bars that heat the wastes. Mixers turn the wastes to provide complete incineration, and liquids may be injected into a secondary combustion chamber. Because all incinerators must meet DREs as specified in 40 CFR 761.75, a specific vendor rather than incinerator type will be chosen.

2.2.11 Non-Thermal Treatment (On-Site and Off-Site)

The following non-thermal PCB treatment technologies are reported by Sworzyn and Ackerman (1981):

- Activated Carbon Adsorption Processes,
- Catalytic Dehydrochlorination,
- Chlorinolysis,
- Goodyear Process,
- Microwave Plasma,
- Ozonation Processes,
- Photolytic Processes,
- Sodium-Oxygen-Polyethylene Glycol,
- Sunohio Process,
- Catalyzed Wet Air Oxidation,
- Activated Sludge,
- Trickling Filter, and
- Special Bacterial Methods.

Only catalyzed wet air oxidation, activated sludge, special bacterial methods, and sodium-oxygen-polyethylene glycol (chemical treatment) are applicable to contaminated soils.

2.2.11.1 Catalyzed Wet Air Oxidation

Catalyzed wet air oxidation is a process in which high temperatures (320° F to 644° F) and elevated pressures of 451 pounds per square inch (psi) to 2503 psi are used to oxidize sludges to alcohols, aldehydes, and acids (Sworzyn and Ackerman, 1981). Even higher temperatures will oxidize the organic constituents to carbon dioxide and water. At least one firm has patented a catalyzed wet air oxidation process for destroying PCBs in the presence of oxygen in an acidic aqueous medium at high temperatures. The end products include: carbon dioxide, nitrogen gas, water vapor, volatile organics, and inorganic solids. Vent gases require some type of conventional treatment. Therefore, this technology will be further considered.

000690

2.2.11.2 Activated Sludge Treatment

The activated sludge and similar innovative, biological slurry processes utilize a biological reactor containing microorganisms under aerobic conditions to oxidize organic contaminants to carbon dioxide, water, and microorganism cell mass (Reynolds, 1982). The existence of a mix of PCB congeners appears to enhance biodegradation (Kane and Mehta, 1985). Additions of biphenyl and surfactants also appear to enhance biodegradation. Laboratory scale projects of the activated sludge process show promise. Therefore, this technology will be further considered.

2.2.11.3 Other Biological Methods

The other biological methods differ mainly in the ways in which the microorganisms are physically supported and contacted with the contaminated materials and the means of supplying additional nutrients. The other biological methods consist of trickling filters and landfarms. Trickling filters consists of a gravel or crushed rock matrix that provides a surface on which microorganisms may grow as the contaminated aqueous medium flows over the surface. With this method, an aqueous medium containing only dilute dissolvable PCB isomers may be successfully treated. Because this description does not match the ITS waste characteristics, this method will not be further considered.

On the other hand, landfarming biological methods may be more applicable to the ITS wastes. Landfarming consists of excavating the contaminated soils and spreading them in a thin layer over cleared, tilled soil either on- or off-site. Landfarming relies on the following processes to treat the PCBs:

- Adsorption,
- Immobilization, and
- Biodegradation.

000691

Adsorption and mobility of the PCBs are dependent on the organic carbon content and surface area of the soil onto which the contaminated soil is landfarmed. Aerobic degradation in a landfarm scenario may be enhanced through tilling the soil to provide greater contact of the microorganisms with the PCBs. Griffin, et al. (1978) present a favorable application of landfarming to PCB wastes. Therefore, this method will be further considered.

2.2.11.4 Chemical Treatment

Chemical treatment reduces the toxicity of PCBs by removing chlorine atoms in the presence of heat with an alkali metal polyethylene glycolate reagent (APEG, NaPEG, or KPEG). The proposed mechanisms of the reaction are:

- An alkali metal hydroxide such as potassium hydroxide is reacted with an alcohol such as polyethylene glycol 400 to form an alkoxide.
- The alkoxide reacts with a chlorine atom on the PCB to produce an ether and an alkali metal salt.
- Dechlorination may proceed to complete removal of chlorine atoms, depending on the contact time (Rogers, et al., 1987).

The APEG may even be recovered and reused (Rogers, et al., 1987).

Toxicity studies on the reaction products, such as the Ames test for mutagenicity and bioaccumulations, have produced negative results, meaning that the products are not carcinogenic and do not accumulate in the food chain (Rogers, et al., 1987). Various pilot scale studies show great promise in using this method to remediate PCB contamination. Therefore, this technology will be further considered. However, a treatability study is recommended before implementation at the ITS site.

2.2.12 In Situ Treatment

There are a number of innovative, in situ treatment technologies showing varying degrees of proven effectiveness. The list given on Table 2-2

includes hydrolysis, oxidation, and reduction, all of which are eliminated because they pertain to aqueous wastes. Soil aeration is not eliminated because it is effective for volatile organics such as TCE and may be used in conjunction with bioreclamation for PCBs. Neutralization is not applicable because pH is not a problem. Polymerization and sulfide precipitation are applicable to liquid waste streams and are dropped from consideration for in situ treatment of soil. Other in situ treatment methods include soil washing, chemical dechlorination, glassification, and biodegradation. Soil and climatic conditions play a big part in the applicability and effectiveness of these methods.

2.2.12.1 Solvent Flushing/Soil Washing

Soil flushing, used to remove organic contaminants from soil, is accomplished in an extraction process consisting of passing a solvent gas through the soil. The solvent type must be chosen by conducting a pilot study on its PCB removal efficiency, and the solvent must then be treated or disposed. However, the affinity of PCBs for soil particles render the PCB removal efficiency of this method questionable. Therefore, this method will be eliminated from further consideration.

2.2.12.2 Chemical Dechlorination

Chemical dechlorination processes have been developed in recent years. One technology discussed under "Non-Thermal Treatment" and also used for in situ treatment is chemical detoxification by applying to the soil alkali metal polyethylene glycolate complexes such as APEG, NaPEG, and KPEG which produce rapid dechlorination in open air systems. Laboratory studies show PCBs reduced from 10,000 ppm to 50 ppm under relatively mild conditions (Iaconianni, 1985). Unfortunately, water has an inhibiting effect on the dechlorination process.

Franklin Research Center (FRC) completed the first in situ application of NaPEG in Buffalo, New York in August, 1983. The inhibiting effect of

water rendered the results inconclusive when compared to those results obtained under laboratory conditions. Preliminary toxicity tests show the reaction products to be non-carcinogenic and non-accumulative in the food chain. The climatic conditions (i.e., high humidity and rainfall) make this technology impractical for the ITS site, and the in situ chemical treatment will no longer be considered.

2.2.12.3 Glassification or Vitrification

Glassification has been used with nuclear wastes, and this has led to the development of an in situ process which uses electric current to melt the soils in place. This technique is new but relatively well proven and may be useful at the ITS site; however, a pilot study would be required before full implementation of this alternative.

The method proceeds by sending an electric current through electrodes placed in the ground to the desired treatment depth. The current causes the soil to heat up to 3600oF, which destroys the organic constituents including contaminants. Gases, including carbon dioxide and water vapor, are collected in a specially designed hood and treated. As the crystalline material cools after treatment, it encapsulates the inorganic soil components into a solid mass resembling natural obsidian.

Fitzpatrick, et al. (1986) performed an engineering-scale test in situ using soils contaminated with 500 ppm PCBs. During vitrification, greater than 99.9% of the PCBs were destroyed, and the removal of PCBs from the off-gas system resulted in an overall DRE of greater than 99.9999%. No residual PCBs were found in the vitrified mass.

Benefits of the in situ vitrification process are:

- Safety for workers and public (very few workers will contact contaminated soils),
- Long-term durability of the vitrified mass (greater than 1 million years),

000694

- Destruction of organic contaminants,
- Applicability to a variety of soils, and
- Efficient processing rates (3 to 5 tons/hour).

Various concerns pertaining to this method have already been addressed (Fuerst, 1987). The method produces such high temperatures that bricks are not formed and no cracks have been observed. The glassified soils have been tested for PCBs and the incomplete combustion products dioxins and furans; none have been detected. A laboratory study of the application of glassification to various soil types demonstrates that the method probably works on most soil types. Currently, glassification is being implemented at a Superfund site to remediate surface soil contamination. However, the volume change caused by the void spaces in the soil filling with molten, glassified material may negatively impact the structures on the ITS site.

This method warrants further consideration.

2.2.12.4 Biodegradation

In situ biodegradation may be used to biodegrade PCBs at the ITS site. The method is implemented by spraying the contaminated soils with "acclimated" microorganisms and tilling the soil to provide greater exchange of oxygen until laboratory analyses performed on soil samples taken from the 0.5 to 1 foot treatment depth show a decrease of PCBs to below 25 ppm. Once the treatment level has been attained, the 0.5 to 1 foot of soil is bulldozed aside, and the inoculation/aeration process occurs on the next 0.5 to 1 feet of soil. This set of steps is continued until the desired treatment depth and level have been attained.

At least two vendors in Texas offer in situ PCB-biodegradation services. As of this writing, the vendors' processes remain proprietary information; therefore, little field data exists to verify the effectiveness of the process. This method will be considered further.

SECTION 3
ALTERNATIVES DEVELOPMENT

Alternatives appropriate for the remediation of PCB contamination that is greater than 25 ppm and appears to be isolated to the the upper 2 feet of soil at the site are developed by assembling complimentary technologies. In this section, the technologies composing each alternative are described. From this list, the remedial alternatives will be further screened to select alternatives to undergo detailed evaluation. The screening criteria for the remedial alternatives include:

- Public health and environmental quality impacts and protective-ness,
- Administrative implementability and technical feasibility, and
- Order-of-magnitude cost analyses.

These screening criteria will be discussed in more detail later in this section.

3.1 COMBINATION OF APPLICABLE TECHNOLOGIES INTO PRELIMINARY REMEDIAL ALTERNATIVES

For the most part, technologies must be assembled together into remedial alternatives to provide comprehensive remediation of a site.

Both the National Contingency Plan (NCP) and SARA of 1986 emphasize the consideration of other applicable federal and state laws when implementing remedial alternatives at a Superfund site. In addition, the SARA amendments require that remedial treatments permanently and significantly reduce the mobility, toxicity, and volume of hazardous materials to the maximum extent practicable (Section 121(b)(1)). The EPA guidance document also specifies new requirements for remedial alternatives to be considered at a site.

000696

These alternatives must address:

- 1) No Action,
- 2) Containment option involving little or no treatment, and
- 3) Treatment alternatives including those containing innovative technologies.

Remedial alternatives for each of the above categories will be developed using the remedial technologies previously examined and then evaluated. The preliminary alternatives for soil remediation are listed in Table 3-1. Preliminary support alternatives for surface water control are shown in Table 3-2.

3.2 DESCRIPTION OF PRELIMINARY ALTERNATIVES

The following alternatives pertain to remediation of the upper two feet of soil contaminated with PCBs. The actual depth and extent of remediation will depend on the analyses of soil samples taken along the northern and western boundaries of the proposed remediation zone and at various locations inside the remediation zone after the two feet of soil have been removed. Figure 3-1 outlines the remediation zone and the proposed sample locations. At least two samples be collected in the ditch along Mansard Street around the location of the former sediment samples containing 47 ppm PCBs to determine the existence of a "hot spot" in the ditch. If PCB contamination greater than 25 ppm is found in a sample, then either the areal boundary or the depth limit, as required, will be extended at and adjacent to the contaminated point so that the contaminated soil is removed, and additional soil samples will be collected. Total volumes of soils to be remediated have been rounded up to account for the existence of the "hot spots". Dust control measures shall be invoked during remediation activities that disturb the soil to prevent further contamination of soils or exposure of workers to dust.

These soil alternatives may be combined with a temporary, supporting alternative for controlling surface water actions. Additional supportive

000697

TABLE 3-1. PRELIMINARY ALTERNATIVES FOR SOIL REMEDIATION

Alternative	Component Technologies
1	No Action
2	Capping and Revegetation
3	Excavation and On-Site Landfill
4	Excavation and Off-Site Landfill
5	Excavation, Stabilization, and On-Site Landfill
6	Excavation, Stabilization, and Off-Site Landfill
7	Excavation and Off-Site Incineration
8	Excavation and On-Site Incineration
9	Excavation and Catalyzed Wet Air Oxidation
10	Excavation and Activated Sludge Treatment
11	Excavation and Contained Landfarm
12	Excavation and Chemical Treatment
13	Excavation and Solvent Flushing or Soil Treatment
14	In Situ Chemical Dechlorination
15	In Situ Glassification
16	In Situ Biodegradation

000698

TABLE 3-2. PRELIMINARY SUPPORT ALTERNATIVES FOR SURFACE WATER CONTROL

Alternative	Component Technologies
1	No Action
2	Retention; Testing; Discharge
3	Retention; Testing; Biological Treatment; Discharge
4	Retention; Testing; Physical Treatment; Discharge
5	Retention; Testing; Discharge to POTW
6	Retention; Testing; Deep Well Injection

669000

3-5

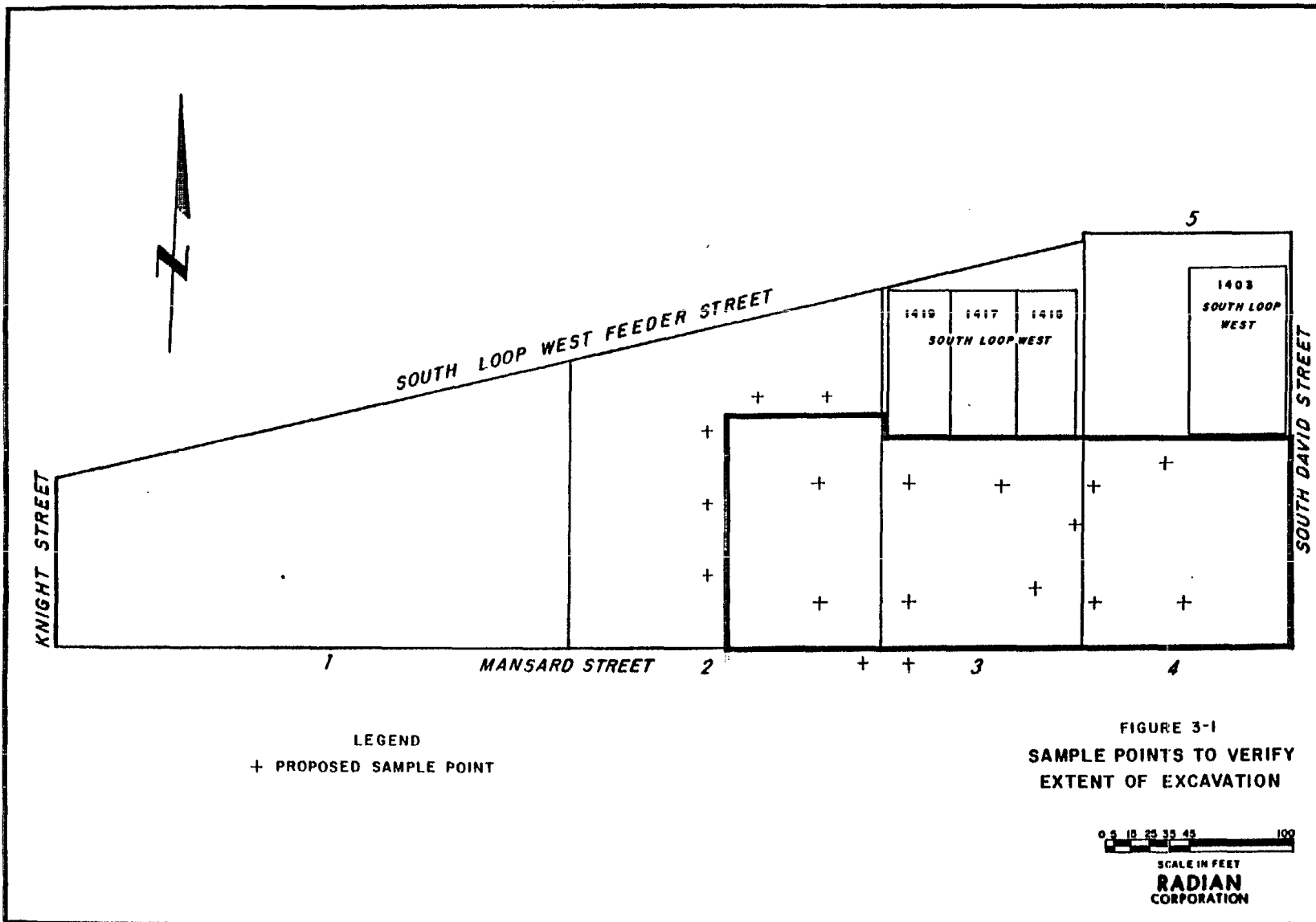

LEGEND
 + PROPOSED SAMPLE POINT

FIGURE 3-1
 SAMPLE POINTS TO VERIFY
 EXTENT OF EXCAVATION

0 5 15 25 35 45 100
 SCALE IN FEET
 RADIANT
 CORPORATION

000700

alternatives may be combined with the soil remedial actions to further protect public health by controlling dust through dust control actions and preventing erosion with revegetation.

3.2.1 Alternative 1 - No Action

For this alternative, no new or additional remedial activities will be conducted. However, long-term activities, including soil, water, and sediment sampling, are associated with this alternative to monitor the contamination. Additional costs accompanying "No Action" are closeout of the Remedial Investigation facilities including removal of the decontamination pad and the monitoring wells.

This alternative does not address public health or environmental concerns. No Action does not meet cleanup guidelines specified by state or local laws. Since this remedial alternative does not permanently or significantly reduce the mobility, toxicity, or volume of the PCB wastes in the upper two feet of soil, this alternative also violates the SARA recommendations. With this alternative, the PCBs remain in the soil on-site, and the public health threat from direct contact or inhalation of airborne PCBs that initiated this Superfund investigation still exists. Therefore, the No Action alternative is included only as a baseline to which other alternatives may be compared.

3.2.2 Alternative 2 - Capping And Revegetation

With the capping and revegetation alternative, the contaminated soil must be covered with an impervious surface to prevent erosion, off-site transport of soil and/or waste materials, and infiltration of rainwater. Cover material consisting of synthetic membranes, clay, asphalt, concrete, or a combination of materials will be placed over the existing contaminated soils, and top soil will be placed on top of the cap and planted with vegetation appropriate to the climate and maintenance requirements. This alternative does not allow for treatment or even permanent immobilization of the wastes but does

prevent contact of the PCBs with air and water as long as the cap remains intact to eliminate the surface water, airborne, and leaching of groundwater contaminant pathways. Capping materials generally have a design life of 30 to 100 years.

3.2.3 Alternative 3 - Excavation and On-Site Landfill

This alternative commences with the excavation of the upper two feet of soils on the site contaminated with greater than 25 ppm PCBs. Excavation may be accomplished with front-end loaders and dozers and removal of the soils with dump trucks to a landfill on-site. Sampling during excavation may discover "hot spots" requiring greater than two feet to be excavated. The excavation shall be covered with one foot of compacted soil fill and one foot of topsoil hydromulched with grass to decrease erosion. The on-site landfill alternative will require the following supportive technologies for proper implementation: dust control, surface water control, waste pile storage, and finally, revegetation.

The Code of Federal Regulations (40 CFR 761.75) specifies that the following requirements be met for PCB landfills, either on- or off-site:

- The landfill shall be located in a site with soils high in clay and silt content exhibiting the following parameters:
 1. Compacted soil liner thickness of 3 feet,
 2. Permeability less than or equal to 1×10^{-7} cm/sec,
 3. Thirty percent of the soil passing a Number 200 Sieve,
 4. Liquid Limit greater than 30, and
 5. Plasticity Index greater than 15.
- Synthetic liners shall be used if the EPA Regional Administrator feels they are necessary.
- The bottom of the landfill liner shall be at least 50 feet from the historical high water table.
- Existing above the 100-year floodwater elevation, the landfill site shall be equipped with diversion structures capable of diverting all of the run-off generated by the 24-hour, 25-year storm.

- Surface water monitoring requirements must be met.
- Groundwater monitoring requirements must be met.
- A leachate collection monitoring system shall be installed above the chemical waste landfill liner and monitored monthly. The leachate shall be treated to acceptable limits for discharge or disposal. The system shall consist of a gravity flow drainfield installed above the liner topped by a secondary liner. Lysimeters shall also be installed.

To fulfill the PCB chemical waste landfill requirements, the landfill design will include installation of leachate collection and leak detection systems installed above the liner. Specifically, this system consists of three feet of compacted soil or clay with a permeability of less than 1×10^{-7} cm/sec separated from an upper layer of high density polyethylene liner (HDPE) by one foot of sand containing the leachate collection and removal system. The layer of HDPE is covered by a thin layer of soil on top of which the waste materials may be placed. Collected leachate, if any, will be treated or disposed with collected run-off. Groundwater monitoring beneath the site and the surrounding area will be accomplished by the installation of at least three wells equally spaced on a line through the center of the disposal area and extending from the highest water table elevation to the lowest on the property. Sampling for PCBs and TCE in the groundwater must occur at least semiannually once the landfilling operations have ceased. To monitor soil moisture and possible migration of contaminants in the unsaturated zone, at least four lysimeters will be installed around the perimeter of the landfill. Samples will be collected from the lysimeters on the same basis as the monitoring wells. A permanent fence will surround the landfill.

The estimated amount of soil requiring excavation to build an on-site landfill on 3/8 acre of land is 8350 cubic yards. Dust and surface water control measures will be employed during the excavation. The construction sequence will include, in order: excavation and construction of the landfill, excavation of the contaminated soils to a waste pile, transport of the contaminated soil from the waste pile to the landfill, spreading and compacting of the contaminated soils in the landfill, and finally, placement of the landfill cap.

The landfill cap shall consist of three feet of compacted clay placed in six inch lifts over the waste soils. A synthetic liner will be placed on top of the clay. A drainage layer consisting of a lower geotextile net layer, topped by twelve inches of sand, and an upper geotextile layer shall be covered by topsoil and hydromulched with grass seed. The cap will require maintenance such as mowing, revegetation, fertilizing, and topsoil replacement.

3.2.4 Alternative 4 - Excavation and Off-Site Landfill

The excavation and removal of contaminated soils to an off-site landfill alternative must be implemented with the support technologies of dust and surface water controls and waste pile storage. Once the contaminated soils have been removed, the excavation must be backfilled with one foot of compacted soil and one foot of topsoil and revegetated. Contaminated soils on the site are excavated with the use of dozers, front-end loaders, and dump trucks to a depth of two feet, and samples taken to detect "hot spots" for additional soil removal. Soils will be stored in temporary waste piles until they are trucked in bulk in accordance with the Department of Transportation (DOT) regulations to an off-site landfill specifically permitted for the disposal of PCBs and in compliance with the Superfund Off-Site Disposal Policy.

3.2.5 Alternative 5 - Excavation, Stabilization, and On-Site Landfill

This alternative will follow the details listed under Alternative 3 with one exception: before transporting the contaminated soils from the waste pile to the on-site landfill, the soils will be mixed in batches in a cement mixer with stabilizing materials such as cement kiln dust or fly ash. The amount of ash added to the contaminated soils may approach 100 percent of the waste volume. Water will also be added to ensure adequate mixing and to add ease in handling. The stabilized wastes will then be spread in the landfill. The stabilized materials increase the volume to be landfilled by at least 50 percent; but the stabilization is thought to improve the immobilization characteristics of a landfill.

000704

3.2.6 Alternative 6 - Excavation, Stabilization, and Off-Site Landfill

This alternative is similar to Alternative 4 - Excavation and Off-Site Landfill. However, for this alternative, the soils will be taken from the temporary waste pile and processed in batches with stabilizing materials such as cement kiln dust or fly ash. The soils will then be placed in the dump trailer for transport by select carrier to an off-site landfill specifically permitted for the disposal of PCBs which is in compliance with the Superfund Off-Site Disposal Policy.

3.2.7 Alternative 7 - Excavation and Off-Site Incineration

The excavation/off-site incineration alternative requires the following support technologies for proper implementation: surface water controls, temporary waste pile storage, topsoil replacement, and revegetation of the excavation. Excavation of two feet of soil, transport, and regrading will be as described for Alternative 4. The soils will be transported in bulk under DOT regulations to an off-site, commercial incineration facility in compliance with the Superfund Off-Site Disposal Policy. The ash disposal and air emission controls will be the responsibility of the incineration vendor.

3.2.8 Alternative 8 - Excavation and On-Site Incineration

This alternative consists of excavating contaminated soils and incinerating them on-site. Support technologies corresponding to this alternative are: surface water control, temporary waste pile storage, topsoil replacement, and revegetation of the excavation. Excavation (two feet of soil) will be by dozer and front-end loader as described for Alternative 3. Incinerator type will be chosen to meet the incineration DRE listed in 40 CFR 761.70, and based on cost and availability.

The ash produced will be classified hazardous and may be disposed by on-site landfill (as described in Alternative 3), off-site landfill (as described in Alternative 4), or it may be tested for hazardous waste charac-

teristics and appropriate Appendix VIII parameters and reclassified as non-hazardous waste. If successfully reclassified, the ash may be disposed on-site (potentially in the excavation left from soil removal) or off-site in a Class II or Class III landfill.

Air emission controls will be the responsibility of the incineration vendor and usually include wet scrubbing. The scrubber water will be classified hazardous unless tested and reclassified. If classified hazardous, the scrubber water will most likely be treated and trucked to a deep well injection facility for disposal. If reclassified, the scrubber water may be treated and discharged with the storm water.

3.2.9 Alternative 9 - Excavation and Catalyzed Wet Air Oxidation

This alternative encompasses excavation of the contaminated soils as previously described, storage in temporary waste piles, and transfer to the reactor vessel in batches for treatment. While in the reactor vessel, the soils will be heated to a temperature of 320°F to 644°F and pressurized to 450 per square inch (psi) to 2500 psi in the presence of a catalyst to oxidize and destroy the PCBs. Unreacted PCBs remain in the reactor until destroyed while carbon dioxide, nitrogen gas, water vapor, volatile organics, and inorganic solids leave the reactor (Sworzyn and Ackerman, 1981). A treatment system will collect the volatile organic gases and treat them prior to venting to the atmosphere.

The soils coming out of the reactor will be stored in separate waste piles. If analyzed and delisted, the treated soils may be backfilled on-site in the excavation; otherwise, the soils will require transport off-site to a permitted landfill for disposal.

3.2.10 Alternative 10 - Excavation and Activated Sludge Treatment

This alternative encompasses the excavation and treatment of the contaminated soils with the activated sludge method. The construction sequence will be:

- Excavation of contaminated soils,
- Stockpiling in temporary waste piles,
- Batch processing of the soils in the activated sludge unit,
- Delisting and discharge of the clarified effluent, and
- Disposal of the sludge.

The activated sludge unit consists of a concrete tank supplied with mechanical aerators and a clarifier which separates the solids (including microbes) and aerated liquid, and then recycles the solids. Water, such as rainfall run-off, will be added to the soils to make a slurry which promotes better contact between the microbes, the PCBs (food source), and the oxygen. As the process proceeds, the microbes release carbon dioxide, water, and other soluble end products such as ammonium, nitrates, nitrites, and phosphates. The carbon dioxide is released to the atmosphere while the water and other soluble end products pass through the clarifier to the final settling tank for testing before final discharge or disposal. The final effluent must meet all requirements of an NPDES permit prior to discharge. The solids are recycled to the aeration basin.

Sludge samples will be collected and tested to determine if adequate biodegradation of the PCBs has occurred. If so, the sludge will be removed from the unit, dewatered, and stockpiled until it can be backfilled on-site. If the sludge shows an inadequate amount of biodegradation has occurred, the aeration and testing will be continued. Water from the dewatering unit will be returned to the activated sludge unit.

Prior to design or implementation of this alternative, a treatability study will be necessary.

3.2.11 Alternative 11 - Excavation and Contained Landfarm

This alternative includes excavating the contaminated soils and landfarming them in a contained setting on the eastern portion of the site. The following steps are required to implement this alternative:

- Excavate and stockpile the upper two feet of contaminated soil,
- Excavate and stockpile enough clean soil to create a dike area to contain the soils to be landfarmed and any run-off generated by the 24-hour, 25-year storm,
- Line the diked area with HDPE and weld the seams,
- Cover the liner with 0.5 to one foot of soil to protect it during tilling activities,
- Commence landfarming by spreading the PCB-contaminated soils in a 6 inch layer,
- Till to a depth of eight to ten inches daily,
- Analyze soil samples and continue tilling until the 25 ppm limit is met,
- Apply another six inch layer of contaminated soil, and repeat the process until all soils have been treated.

000708

Various other technologies will also be utilized. During all heavy equipment activities, dust control measures will be implemented. The diked area will collect all rainfall run-off, which requires testing before treatment or disposal. Once the landfarming activities are complete, the soils may be delisted and backfilled in the original excavation.

A treatability study is necessary prior to implementation of this alternative at the site.

3.2.12 Alternative 12 - Excavation and Chemical Treatment

This alternative is similar to Alternatives 9 and 10 in that the contaminated soils are excavated, stockpiled, treated in a reactor vessel, tested, and finally backfilled into the original excavation. This alternative differs in the type of reactor and the nature of the treatment process.

The reactor vessel for the chemical treatment alternative will consist of a special reactor vessel containing a boiler, cooling system, laboratory, and control room. Stockpiled, contaminated soils will be placed into the

mixer with the APEG reagent and mixed until testing shows the PCBs have been dechlorinated to the desired level. The treated materials will be dumped into a dewatering unit which will separate the solids (to be stockpiled for backfilling into the original excavation) and the liquids, which will be recycled to the reactor.

A treatability test is necessary prior to implementation of this alternative.

3.2.13 Alternative 13 - Excavation and Soil Flushing/Solvent Washing

This alternative encompasses excavating the contaminated soils and removing the PCBs using a solvent extraction process. The soils are excavated as previously discussed and passed through a pressurized fluid extraction unit which uses a solvent gas to extract the organic contaminants. A treatability study would determine the type of solvent gas. The resulting concentrated waste organic carbon would be disposed at an incinerator in compliance with the Superfund Off-Site Disposal Policy. The treated soils, once delisted, could be backfilled into the original excavation.

Dust and surface water controls would be employed during excavation activities. Collected rainwater and decontamination water may also be treated in the extraction unit from which they will pass into a precipitation/clarification unit before testing and discharge. The sludges from the precipitation/clarification unit will be taken to an off-site landfill in compliance with Superfund Off-Site Policy.

3.2.14 Alternative 14 - In Situ Chemical Dechlorination

Alternative 14 includes the treatment of the contaminated soils by applying an alkali metal polyethylene glycolate complex such as NaPEG, KPEG, or APEG to the soil. Implementing this alternative requires clearing the brush off the soil surface, applying the chemicals, tilling the soil to improve

chemical contact with the PCBs, covering the site with plastic to keep rain off the site, and periodic analytical testing to determine the amount of PCB destruction that has occurred. Dikes are an important support technology to prevent rainfall run-on from entering the site because water inactivates the polyethylene glycolate complexes. Unfortunately, a successful field scale trial of in situ chemical treatment with alkali polyethylene glycolate complexes has not yet occurred within an adequate time frame. Therefore, a pilot scale test at the ITS site will be necessary before full-scale implementation.

Once reaching the desired level of contamination of 25 ppm or less PCBs, the soil will require erosion protection, which can be accomplished by revegetating the surface.

3.2.15 Alternative 15 - In Situ Glassification

In situ glassification, or vitrification, offers the greatest degree of containment of all common solidification methods in addition to organics destruction. This innovative method developed at Battelle Pacific Northwest Labs uses an electric current passed between electrodes in the ground to heat the soils to a very high temperature (3600°F) and convert them into a stable crystalline material resembling natural obsidian. Most glassified soils produce tensile and compressive strengths approximately ten times those of unreinforced concrete and can survive weathering within a time frame of geological magnitude.

Implementation of the process will require power in the form of locally supplied electricity. An off-gas collection and treatment system will be added to remove the gases that evolve from the process. Because glassification provides for both impervious barriers for groundwater, surface water and surface stabilization for vehicle support, the site will require only the supportive technologies of replacing topsoil on the vitrified mass and vegetation of the topsoil. Vegetation will be limited to those varieties that can support themselves in the amount of topsoil to be backfilled on top of the

000710

vitrified wastes. Glassification is an innovative alternative and can survive a negative cost evaluation. However, a pilot scale test is recommended before full-scale implementation.

3.2.16 Alternative 16 - In Situ Biodegradation

The in situ biodegradation alternative consists of biologically degrading the PCBs in place. To meet this end, dikes are built around the perimeter of the soils to be remediated. The entire area is sprayed with a mixture of acclimated microbes and nutrients, and then tilled to a depth of 6 inches to mix the soils and microbes and to provide a greater oxygen supply. Tilling will occur every day. Once laboratory analyses from soil samples show the PCBs have biodegraded to less than the 25 ppm level, the top 6 inches of soil is bulldozed aside to a temporary waste pile and the process is repeated until the top 2 feet have been treated. Then the treated soils will be back-filled into the treatment area and revegetated. Dust and surface water controls will be utilized during the treatment period. Collected rainwater will be stored in a temporary tank, tested, and discharged or disposed by deep well injection. A treatability study is necessary prior to implementation of this method at the ITS site.

3.3 SURFACE WATER CONTROL ALTERNATIVES

The following alternatives discussing surface water remediation are support technologies for the soil remediation alternatives. These water remedial alternatives also apply to water generated by decontamination and dust control activities. The areas of concern requiring these water remedial alternatives are: the remedial area (or contamination zone), waste pile staging area, decontamination zone, and also the support area. Not all soil remediation alternatives will require surface water controls.

Total costs have been calculated for the surface water alternatives. The costs have been normalized to a per year basis to enable comparisons between alternatives. The detailed cost estimates are shown in Appendix A.

000711

3.3.1 Alternative 1 - No Action

The surface water no action alternative encompasses employing no technologies to control surface water run-off. The total yearly cost of this alternative is \$0.

3.3.2 Alternative 2 - Retention, Testing, And Discharge

This diversion/collection alternative consists of retaining and testing run-off collected from the work areas in a retention basin or temporary storage tank and then discharge. Diversion of run-on from off-site and collection of run-off on-site will be accomplished by constructing dikes or berms of well-compacted clayey soil fill, most likely obtained from off-site, forming a retention basin. The fill material will be hauled by dump trucks and spread by dozers. The surface inside the diked area shall be graded so that drainage will collect at one end. The dike must be high enough to contain the 24-hour, 25-year storm as specified in 40 CFR 761. Periodic inspection and maintenance of the dike will be required. An outlet structure made of concrete culvert with a closing valve should be placed at the low end of the retention basin. After every storm event, the collected run-off will be chemically analyzed. If the water meets the required criteria, it may be discharged directly to a receiving body. An NPDES permit is not required for the discharge of treated water, but the technical standards required by such a permit must be met before discharge may occur. Sampling frequency and parameters will be determined by permit requirements.

The surface water receives only monitoring for this alternative, but monitoring may be the only action necessary to protect public health and the environment. This surface water alternative will be implemented in conjunction with a soil remediation alternative. The total yearly cost is \$97,850.

000712

3.3.3 Alternative 3 - Retention, Testing, Biological Treatment, And Discharge

This retention/treatment waste alternative results in biological treatment of the collected surface water. Upon collection from the site, with the retention basin previously described, the run-off will be diverted to a temporary storage tank where biological treatment occurs. Both TCE and PCB can be biodegraded aerobically or anaerobically. Once meeting NPDES permit standards, the effluent can be discharged to a receiving body.

The biological treatment can consist of an aeration basin designed to enhance aerobic respiration. The treated water will need to pass through a settling basin or sand filter prior to discharge to remove suspended solids. This complicated alternative will require large capital costs, a knowledgeable, trained staff to ensure quality effluent, and substantial maintenance costs. However, if batch biological treatment in a reactor vessel is chosen for remediation of soil contamination, the run-off could be treated by the same system with the soils. Bench scale studies would be required before implementation of this alternative. The total yearly cost is \$124,153.

3.3.4 Alternative 4 - Retention, Testing, Physical Treatment, And Discharge

Alternative 4 includes the diversion of rainwater followed by temporary storage before physical treatment and discharge. Upon collection in the previously described retention basin or storage tank, the stormwater can be temporarily stored there until it can be run through parallel columns filled with activated carbon, which will remove the organic contaminants from the water. The water may be discharged to a receiving stream from the columns as long as its quality meets those standards specified in NPDES permits. As with other surface water alternatives, this alternative is only a supportive measure to be used with a soil remediation scheme.

Additional costs involved with this alternative include periodic flushing of the carbon column, disposal of the spent carbon in a facility that

conforms to the Superfund Off-Site Disposal Policy (such as a chemical landfill or incinerator), and maintenance of the retention basin. This alternative allows for removal of contaminants as specified by public health considerations and will be considered in more detail. Pilot studies may be required before implementation of this alternative. The total yearly cost is \$117,045.

3.3.5 Alternative 5 - Retention, Testing, and Discharge To A Publicly Owned Treatment Works

Alternative 5 deals with diversion and collection of surface water and subsequent discharge to a POTW. After the run-off has been collected in the previously mentioned retention basin or storage tank, it will be routed to a publicly owned treatment works. This alternative requires a city permit and is only included to be used as a support method with a soil alternative; however, the city may require periodic sampling or pretreatment prior to discharge to the POTW.

Collection/diversion with discharge to a POTW is a desirable method of disposing the run-off because the operating costs are lower than those for other alternatives amounting to only the dike, storage tank, and sewage discharge fees (pretreatment will cost more). Furthermore, the run-off will receive adequate treatment to protect public health and the environment prior to discharge to a receiving body. The total yearly cost is \$103,131.

3.3.6 Alternative 6 - Retention, Testing, Transport, And Deep Well Injection

This alternative encompasses diversion/collection of run-off followed by deep well injection. Once contained in the retention basin or storage tank as previously described, the run-off and decontamination pad water can be shipped via vacuum truck to a deep well injection facility, the nearest of which is approximately 15 miles away. Transport considerations include truck weight limitations, choosing the proper route through town, and maneuverability of the truck so that the storage tank can be reached and traffic will not be blocked.

Analyses for PCBs and dissolved solids must be performed on a representative sample prior to acceptance by the facility. Water quality could vary greatly depending on the length of the storm event, the amount of wind, etc. While this is a desirable, cost-effective method, the possibility exists that the facility will reject the water based on the chemical analyses, and will require pretreatment of the water before disposal. In addition, high solids content could greatly increase the cost of deep well injection since those facilities charge by the pound of solids removed. Alternative 6 will only be implemented as a support alternative for a soil remediation scheme. The total yearly cost is \$128,435.

3.4 SCREENING OF ALTERNATIVES

In this section, the preliminary alternatives will be compared to each other based on effectiveness (ability to reduce public health and environment impacts), implementability, and order of magnitude costs. The alternatives clearly not equivalent in terms of effectiveness and implementability to the others will be eliminated from consideration. Costs will be considered secondary to effectiveness, particularly for innovative alternatives.

Effectiveness as used here refers to the ability of an alternative to reduce public health risk and adverse environmental impacts compared to the "No Action" and other alternatives.

The implementability of each alternative is screened to determine the ease of installation and construction for an alternative. Implementability also concerns the time required to achieve a certain level of remediation. Table 3-3 summarizes the preliminary screening of the alternatives.

Costs are estimated based on preliminary concepts and are intended to be only -30% to +50% accurate. They are based on a 4% interest rate. Costs calculated at a 7% and a 10% interest rate are presented in a later section of this study. The purpose of this preliminary analysis is to screen out alter-

TABLE 3-3. PRELIMINARY SCREENING OF ALTERNATIVES FOR SOIL REMEDIATION

Alternative	Types of Remediation	Warrants Further Consideration
1. No Action	None	Yes
2. Capping and Revegetation	Immobilization	No
3. Excavation and On-Site Landfill	Immobilization	No
4. Excavation and Off-Site Landfill	Removal/Immobilization	Yes
5. Excavation, Stabilization, and On-Site Landfill	Immobilization	No
6. Excavation, Stabilization, and Off-Site Landfill	Removal/Immobilization	Yes
7. Excavation and Off-Site Incinerator	Removal/Destruction	Yes
8. Excavation and On-Site Incinerator	Destruction	Yes
9. Excavation and Catalyzed Wet Air Oxidation	Destruction	No
10. Excavation and Activated Sludge Treatment	Destruction	Yes
11. Excavation and Contained Landfarm	Destruction	Yes
12. Excavation and Chemical Treatment	Destruction	Yes
13. Excavation and Soil Flushing/Solvent Washing	Removal	No
14. In Situ Chemical Dechlorination	Destruction	No
15. In Situ Glassification	Destruction	Yes
16. In Situ Biodegradation	Destruction	No

000716

natives which provide a similar level of public health and environmental protection but at an order of magnitude or greater cost. Costs for a five year review are included in the operation and maintenance costs for each alternative. These costs are presented in detail in Appendix B.

3.4.1 Alternative 1 - No Action

The no action alternative will not eliminate any routes of exposure. However, the existing routes are discussed here so that the effectiveness of the other alternatives in reducing the effects of the exposure routes can be judged.

The potential routes of exposure to the PCBs at the ITS site include:

1. Inhalation of dust contaminated with PCBs that becomes airborne,
2. Direct contact with contaminated soils,
3. Ingestion of contaminated soils, and
4. Direct contact or ingestion of run-off water.

The routes of primary public health concern are inhalation or direct contact with PCB-contaminated dust and particles. Data from the RI show PCB levels in the upper two feet of soil ranging from none detected to 220 ppm. The air quality sampling showed no PCB-contaminated particles in the air at the time of sampling. However, construction at the site has the potential to entrain contaminated particles in the air.

Varied populations are potentially exposed to direct contact with contaminants at the ITS site. According to the 1980 Census Data for Houston, approximately 2,060 people reside within a 1-mile radius of the site. A transient population of about 100,000 persons peak daily attendance is observed at the recreational complexes of the Astrodome, Astroworld, and Waterworld. However, these people would not be likely to come into contact with material from the site. An additional 250 people work within 0.5 mile of the site. These and workers at the four businesses on the site are the most likely to contact contaminated material via foot traffic and inhalation.

000717

Aquatic organism, avian species, and terrestrial organisms may also be exposed to PCBs washed from the site by surface water.

Effectiveness - The pathways of concern are inhalation of airborne dust, direct contact with soil, direct ingestion of soil, and direct contact or ingestion of run-off water. While none of these is an immediate threat to human health or the environment, the no action alternative does not eliminate the long-term threat to workers from inhalation. The effectiveness of remedial action alternatives will be judged based on their ability to reduce or eliminate these pathways in the long term, without making the contaminants more active during construction.

Implementability - The no action alternative is relatively easily implemented. However, every five years the site would be reassessed to determine whether no action should be continued.

Cost - The only costs associated with the no action alternative are monitoring soil, water, sediments, and air semiannually; closing out the RI decontamination pad; and plugging most of the monitoring wells. The present worth of the monitoring costs, with a 4% interest rate for 30 years, is estimated to be \$202,432.

3.4.2 Alternative 2 - Capping and Revegetation

Effectiveness - This alternative provides for immobilization but not destruction of the PCBs. Capping and revegetation will be effective in controlling all four pathways of concern. The contaminated material will not be moved; therefore, the migration along these pathways will not be appreciably accelerated during construction. Care will be taken during removal of existing vegetation and during any other work that may disturb the material to suppress dust and capture any run-off. Therefore, this alternative will be effective.

Implementability - The cap materials may be readily applied to the site once the brush has been cleared off. Implementation may take one to two months, and construction activities could be hampered by wet weather. However, a cap over the surface soils would require a three to four feet increase in surface elevation (for clay caps - a multimedia cap would require somewhat less material) at the capped area. This elevation increase would interfere with business activities at the four addresses at the 1400 block of the South Loop West, an undesirable effect.

Therefore, this alternative is screened from further consideration.

3.4.3 Alternative 3 - Excavation and On-Site Landfill

Effectiveness - This alternative, while providing immobilization but not destruction of the PCBs, will be effective in the long-term in controlling the four migration pathways. In the short-term, during construction, care will be required to control dust and run-off. Also, safety procedures will be used to prevent direct skin contact during excavation and placement. However, these precautions will not be a problem to implement. Therefore, all four pathways can be controlled.

Implementability - While an on-site landfill may be readily constructed, several factors prevent this alternative from being implemented on-site. First, 40 CFR 761.75 specifies that the landfill liner must be at least fifty feet above the historical high water table. The depth to the water table from the ground surface at ITS is only approximately thirty feet. Second, the only on-site land on which a landfill may be built (Area 1 and the western part of Area 2) is uncontaminated and belongs to a party not associated with the ITS site. Both the State and the EPA have expressed reluctance in purchasing and retaining title to land that holds a PCB landfill. In addition, TWC and EPA prefer not to place contaminated materials in a landfill on clean soils.

Therefore, this alternative is screened from further consideration.

3.4.4 Alternative 4 - Excavation and Off-Site Landfill

Effectiveness - The migration pathways will be controlled as discussed for Alternative 3 by removing the contaminants off-site and immobilizing them. Care will be taken during transport to prevent exposing or spilling the material. Truck transport of bulk solids of this type is common, and most transporters are familiar with the necessary precautions. Therefore, this alternative is also effective.

Implementability - Off-site landfilling is another readily implemented alternative. Implementation time will be on the order of 2 months. Excavation and transportation methods of PCB wastes are well known and used by many vendors. At least three landfills exist nationwide that are in compliance with Superfund Off-Site Disposal Policy and will accept the soils from the ITS site.

Cost - The present day worth including a 4% interest rate of the off-site landfill alternative is \$2,017,285.

This alternative will be considered further.

3.4.5 Alternative 5 - Excavation, Stabilization, and On-Site Landfill

Effectiveness - This alternative is effective in controlling the migration pathways as discussed for Alternative 3 by immobilizing the PCBs in an on-site landfill. The stabilizing materials are thought to add immobilizing qualities to the landfill. Dust and surface water control measures plus personal protective equipment for the workers will reduce short-term public health threats.

Implementability - As for Alternative 3, several factors prevent this alternative from being implemented. The on-site landfill cannot meet the fifty feet depth to the seasonal high water table as required in 40 CFR 761.75. In addition, the EPA and the State are reluctant to gain title to land on which a chemical waste landfill resides. The agencies also prefer not to dispose contaminated materials on uncontaminated soils.

Therefore, this alternative will be screened from further consideration.

3.4.6 Alternative 6 - Excavation, Stabilization, and Off-Site Landfill

Effectiveness - This alternative controls the migration pathways as discussed for Alternative 4. The addition of stabilizing material is thought to make the off-site landfill alternative more effective.

Implementability - Stabilization and off-site landfiling is another readily implemented alternative. Implementation time will be on the order of three months. The component technologies of excavation, stabilization, transportation, and disposal are well known and used in the hazardous waste business. At least three landfills exist that are in compliance with Superfund Off-Site Disposal Policy and will accept the PCB-contaminated soils from the ITS site.

Costs - The present day worth of this alternative, including a 4% interest rate, is \$3,173,855.

This alternative will be considered in more detail.

3.4.7 Alternative 7 - Excavation and Off-Site Incineration

Effectiveness - The long-term effectiveness of this alternative is very good because the PCB-contaminated soils are removed. During the excavation and transport, the same controls discussed for off-site landfiling (Alternative 4) will be used and are effective. In addition, the off-site incineration alternative destroys the PCBs with an efficiency of approximately 99.9998%. Remaining PCBs are removed in the scrubber water to yield a DRE of at least 99.9999%.

The air emissions at the incinerator are controlled by permanent scrubbers. The resulting ash and scrubber water will be disposed of as part of the routine operation of the incinerator, and these methods are assumed effective because the facility must be in compliance with RCRA requirements.

Implementability - Off-site incineration may be readily implemented for the ITS site in a two to three month time span. The excavation and removal activities that will be required are proven technologies. Various PCB incinerators operate across the country, but locating a facility that is in compliance with the Superfund Off-Site Disposal Policy may be difficult. Some facilities may require that the soils be placed in fiber packs prior to incineration.

Cost - Off-site incineration exhibits a present day worth of \$5,838,580. This cost includes transportation to an incineration facility, incineration, equipment, labor, materials, engineering and administration costs, and the like.

This alternative will be considered in more detail.

3.4.8 Alternative 8 - Excavation and On-Site Incineration

Effectiveness - On-site incineration effectively controls the pathways of concern by destroying organic contaminants and by scrubbing the incinerator stack gases to remove the air emission pathway. Exposure pathways created during construction can also be effectively controlled during this alternative implementation. The resulting ash may be backfilled (once reclassified) with possible leachate monitoring on-site, or the ash may be disposed at a landfill.

Implementability - On-site incineration will require significant construction on the western portion of the site. This construction will include site clearing, pouring of foundation slabs for the incineration units, and fencing around the equipment. The soils will require controlled stockpiling prior to incineration. In addition, the path over which dump trucks will travel while carrying soils from the stockpile to the incinerator and back may require stabilization with sand or gravel. Dust and run-off control technologies will be implemented. This alternative may require a test burn and treatability studies for the scrubber water prior to full scale implementation.

000722

Time requirements should be approximately two months for the test burn/treatability study and another four months for the treatment itself. Finally the availability of the incinerator units will also affect the implementability of this alternative.

Cost - On-site incineration exhibits a PCB destruction efficiency of 99.9999% at a present day worth of \$2,156,686.

This alternative will be considered further.

3.4.9 Alternative 9 - Excavation and Catalyzed Wet Air Oxidation

Effectiveness - Because this technology is new and not completely researched, the effectiveness of catalyzed wet air oxidation is not known. Over fifty laboratory tests made on five grams of Askarel (56% PCBs and 44% trichlorobenzene) using a one liter stirred reactor showed greater than 90% reduction of PCBs (Sworzyn and Ackerman, 1981). Data has not been provided on the toxicity of the organic byproducts formed during treatment. Special controls such as carbon stripping must be added to control the new air exposure pathway. Exposure pathways created during the excavation may also be effectively controlled during the implementation of this alternative.

Implementability - The excavation techniques are easily implemented for this alternative. However, successful implementation of the catalyzed wet air oxidation may be difficult because field studies on PCB wastes have not yet been conducted.

Therefore, this alternative is screened from further consideration.

3.4.10 Alternative 10 - Excavation and Activated Sludge Treatment

Effectiveness - The activated sludge biological slurry method is intended to destroy the PCBs. Various researchers have reported success in degrading PCBs in this manner. Sworzyn and Ackerman (1981) describe laboratory

testing with a continuous feed activated sludge unit that caused an 81 percent degradation of Arochlor 1221, 33 percent degradation of Arochlor 1016, 26 percent degradation of Arochlor 1242, and 15 percent degradation of Arochlor 1254. A vendor reports successful biodegradation of PCBs in an open bioreactor. Initial PCB concentrations were as high as 2000 ppm in sludges and 44 ppm in the aqueous phase. Through the processes of volatilization, dilution, and biodegradation, the final sample collected four months later indicated a PCB concentration reduction to 4 ppm overall (DeTox,1987). Dust and run-off control measures were implemented to further control the exposure pathways.

Implementability - The technologies encompassed in this alternative are easily implemented at the ITS site. The biological process will require a treatability study prior to full scale implementation at the site.

Cost - The present day worth of this alternative is \$3,062,557.

This alternative will be considered further.

3.4.11 Alternative 11 - Excavation and Contained Landfarm

Effectiveness - Griffin, et al. (1978) and DeTox (1987) have shown landfarming to be effective in immobilizing and biodegrading PCBs. PCBs are strongly and rapidly adsorbed to soil particles. Laboratory data from the study shows 92 percent complete biodegradation of Arochlor 1242 within twenty hours and 98 percent within ten days, and the field studies confirm the mode of microbial degradation found in the laboratory. Therefore, this method shows promise in effectively remediating PCB contamination.

Implementability - The construction methods required for implementation of this alternative are easily attained. A treatability study is recommended prior to full-scale implementation at the site.

Cost - The present day worth of this alternative is \$2,321,046.

This alternative will be considered further.

3.4.12 Alternative 12 - Excavation and Chemical Treatment

Effectiveness - This innovative alternative is also less proven than most of the alternatives. This method will eliminate the pathways of concern in the long-term by dechlorinating the PCBs. In the short-term, during construction, the four pathways of concern can be controlled through the use of dust and surface water controls in addition to personal protective equipment, (PPE), i.e., gloves, hard hats, safety shoes, respirators, etc.

Implementability - The construction methods to be employed for this method are well proven and implementable. The process will require a treatability study prior to implementation.

Cost - The total present worth with a 4% interest rate amounts to \$1,962,334.

This alternative will be considered in more detail.

3.4.13 Alternative 13 - Excavation and Soil Flushing/Solvent Washing

Effectiveness - The effectiveness of this method in remediating the long-term PCB contamination has not been documented. PCBs have a strong affinity for soil particles and it would be difficult to remove them even with a solvent gas. In the short-term, the four exposure pathways of concern can be controlled during construction with PPE for the workers plus dust and surface water control measures.

Implementability - Construction methods to be employed for this method are well proven and implementable, but the innovative treatment process is not well proven and, therefore, is not easily implemented.

Because it is not proven for removing PCBs from contaminated soils, this alternative is eliminated from further consideration.

3.4.14 Alternative 14 - In Situ Chemical Dechlorination

Effectiveness - In situ chemical dechlorination is intended to eliminate the source of contamination. There is documentation that dechlorination can be effective in remediating PCB contamination. Because the technique is innovative and somewhat unproven, a treatability test will be required before a final assessment can be made.

Implementability - The only component that would compromise the implementability of in situ chemical dechlorination at the site is the rainy climate. The wet climate slows the process or inhibits it altogether, preventing effective treatment within a reasonable time period.

Because moisture in the form of rain and humidity would greatly reduce the effectiveness of this alternative, in situ chemical dechlorination is screened from further consideration.

3.4.15 Alternative 15 - In Situ Glassification

Effectiveness - This is an innovative alternative which is less proven than most of the alternatives. However, it will eliminate the pathways of concern in the long-term by thermally destroying and removing 99.9999% of the PCBs while immobilizing the inorganic components of the soils. In the short-term, during construction, the four pathways of concern can be controlled. A new pathway, gaseous air emissions, results from the heated organic compounds, PCBs included, rising out of the molten soil and oxidizing on contact with oxygen in the atmosphere. To control the resulting air emissions, a hood is placed over the area being vitrified, and the oxidation products are collected and passed through a scrubber. Therefore, this alternative also controls the potential migration pathways.

Implementability - Construction methods to be employed for this method are moderately well proven and implementable. The glassification process may require a pilot scale test to determine the most effective elec-

000726

trode spacing and depth for soil treatment. However, the treatment depth of two to three feet at the ITS site is relatively shallow compared to the fifty feet treatment depth possible with the glassification method.

Cost - The total present worth with a 4% interest rate of the in situ glassification process amounts to \$1,200,890. This cost estimate includes dollars for a test run which will be run on a 10 to 20 kilogram sample at the vendor's facilities.

This alternative will be considered in more detail.

3.4.16 Alternative 16 - In Situ Biodegradation

Effectiveness - In situ biodegradation is an innovative method that shows great promise in removing the four exposure pathways in the remediation of soils contaminated with PCBs. Various researchers (DeTox, 1987; Griffin, et al., 1978) have shown varying degrees of success with different PCB mixtures. In addition, the short-term exposure pathways created during tilling may be controlled through the use of dust and surface water control measures in addition to PPE. A treatability study would be required prior to full-scale implementation of this alternative.

Implementability - The construction and biodegradation technologies encompassed in this alternative are easily implemented. Only the blocking of the rear entrances to the businesses at 1415, 1417, and 1419 South Loop West for the length of time the treatment process would require would hinder the implementability of this alternative.

Because this method would require blocking access to the businesses at the 1400 Block South Loop West, this alternative is screened from further consideration.

SECTION 4
DESCRIPTION OF ALTERNATIVES

This section presents a detailed description for each alternative selected in the previous section based on its implementability, public health and environmental impacts, and costs. Each description will address the following points:

- The purpose of the remedial alternative;
- Description of the component technologies comprising the alternative;
- Preliminary conceptual designs;
- Long and short term operation, maintenance, and monitoring requirements for each alternative; and
- Aspects of contamination at the ITS site that the alternative does not address.

The descriptions and preliminary conceptual designs were formulated so that cost estimates could be determined. Major capital expenditures are listed for each alternative, as is the total present worth of the alternative. The total present worth is the total capital cost of the alternative plus operation and maintenance costs for thirty years discounted to 1987 dollars with a 4% interest rate. These cost estimates are shown in more detail in Appendix B. However, the alternatives and their descriptions are not final remedial decisions, and the final designs will be developed based on public input, regulatory agency policies, and additional knowledge derived from further research at the site or concerning a particular remedial technology.

As discussed previously, attaining the 25 ppm PCB remediation level results in the attainment of the 161 ppm TCE cleanup level. The remediation level of 25 ppm in the surface and shallow subsurface soils is attained by all alternatives except "No Action". The 25 ppm PCB level is based on an industrial/commercial type of land use. None of the alternatives, except possibly in situ glassification, would compromise a future groundwater remedy.

4.1 ALTERNATIVE 1 - NO ACTION

The no action alternative will consist of no treatment of the contaminated soils and no operation or maintenance of any type at the facility. However, annual environmental monitoring will be required to assess the migration of the PCBs. Groundwater, soil, and sediment samples will be collected at an approximate cost of \$10,000 per year. Closeout of five of the monitoring wells and the decontamination pad from the RI activities will require two to three weeks. In addition, a review to occur every five years is budgeted into the total costs for a present worth of \$202,432. The costs for this alternative are:

- Capital \$29,512 and
- Annual O & M \$10,000.

The no action alternative contributes to the migration of contaminants at the ITS site and may cause the adjacent populations to be exposed to the PCBs with the entailing risks as identified in the RI. However, as suggested in the EPA guidance document, this alternative must be addressed, as a baseline to which all the other alternatives may be compared.

4.2 ALTERNATIVE 4 - EXCAVATION AND OFF-SITE LANDFILL

The off-site landfill alternative, which addresses the immobilization but not treatment of the PCBs, requires that the upper two feet of soil in the most highly contaminated areas be excavated (as described in Section 3), transported, and disposed at an off-site PCB landfill. Figure 4-1 shows the areal extent of soils to be excavated. Approximately 2500 cubic yards (2850 yd³ with the 15 percent excavation expansion factor) of soil will require excavation and transport 700 miles to an appropriate facility, necessitating over 168 dump trailer loads (about 17 cubic yards per load). Remedial actions for this alternative will generate at least five drums of disposal clothing, that may be disposed at the landfill also.

Figure 4-2 shows a proposed staging plan for this alternative. The dump trailers will enter the site on the east side, receive a full load of soil

4-3

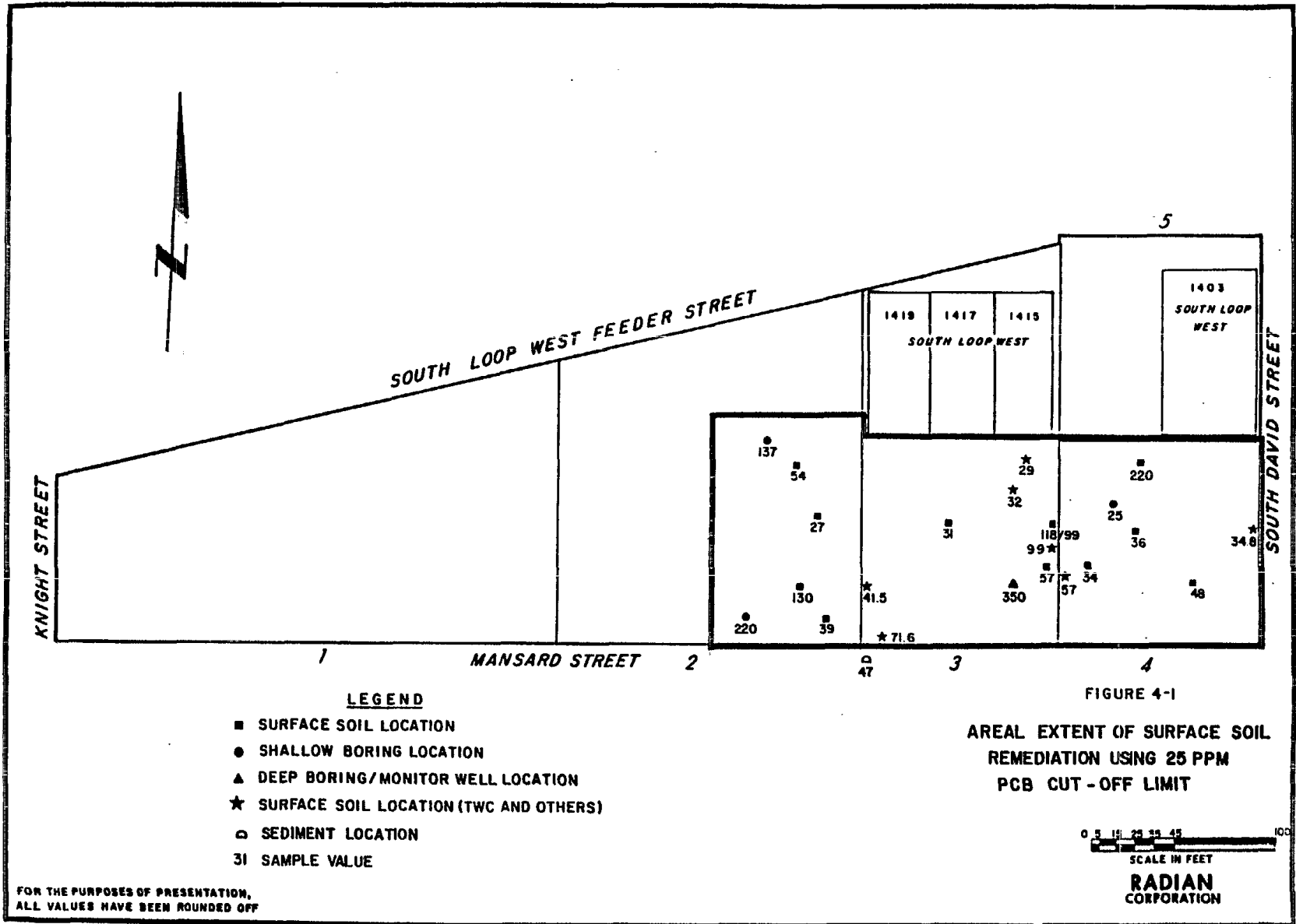

000730

4-4

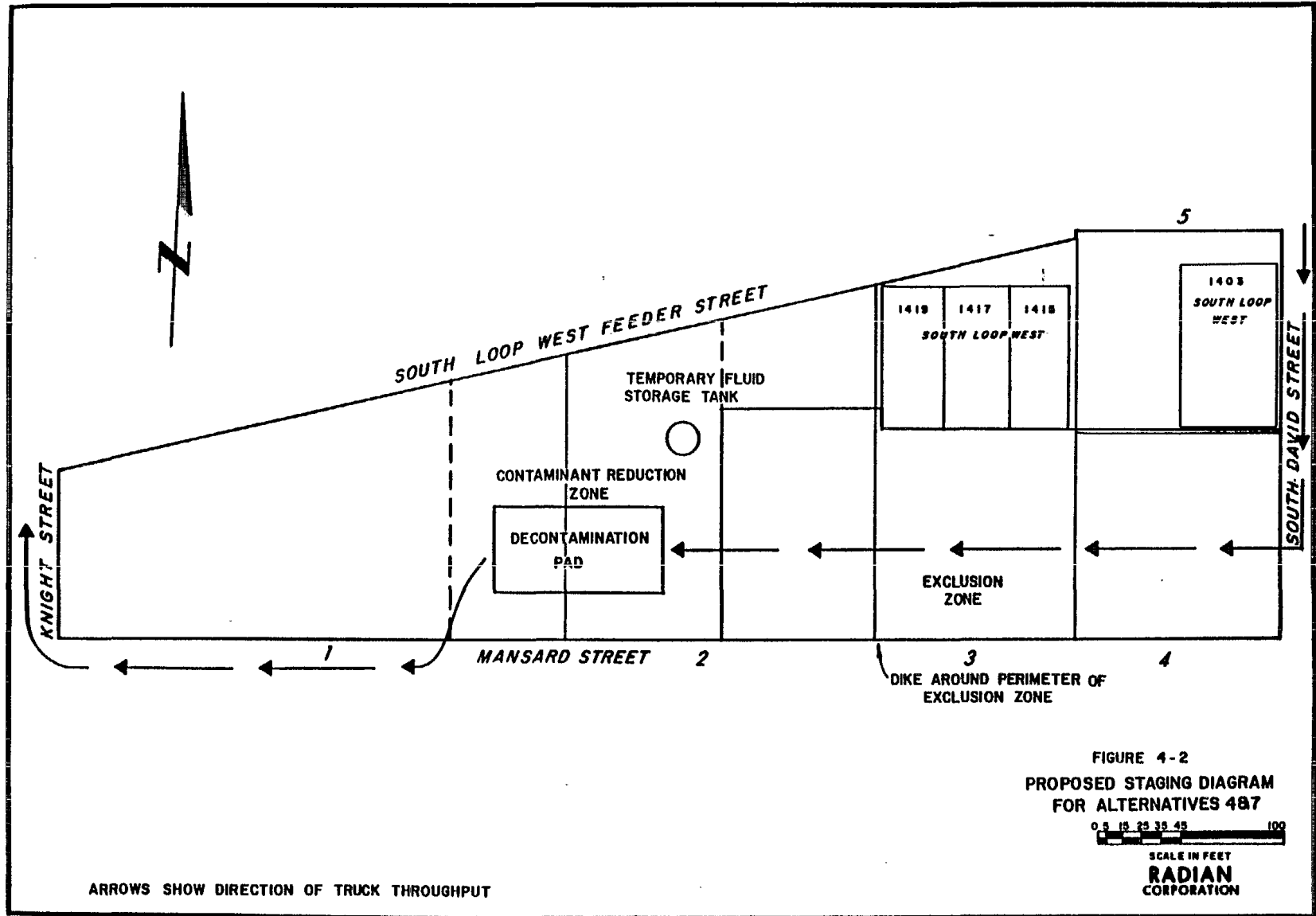

FIGURE 4-2
PROPOSED STAGING DIAGRAM
FOR ALTERNATIVES 487



SCALE IN FEET
RADIAN
CORPORATION

ARROWS SHOW DIRECTION OF TRUCK THROUGHPUT

000731

from the excavation, enter the decontamination pad, and once cleaned, exit to the South Loop via Mansard and Knight Streets. Excavation will commence along the eastern edge of the site and progress westward.

Once excavation of the contaminated soils has been completed, the decontamination pad will be dismantled and transported to the landfill for disposal. The excavation will be filled with topsoil placed in six inch lifts and then seeded with appropriate vegetation.

Long term monitoring after remediation would still be required at the site. Monitoring would be accomplished by collecting soil, water, and sediment samples.

Contaminated liquids will be collected and temporarily stored in a tank near the decontamination pad until properly tested and treated or disposed. Rainfall run-off will be collected with a dike system. The dikes may be constructed along the excavation boundaries so that run-off may be routed to the temporary storage tank. The decontamination pad will be constructed so that the collected fluids may also be stored in the tank. Analytical testing for PCBs will determine whether the water can be discharged to the drainage ditch, sanitary sewer, or transported to an injection well for disposal. The water may require treatment prior to discharge or disposal. Water will be sprayed for dust control during excavation.

While the off-site landfill alternative does not reduce the toxicity of the contaminants, the PCBs will be removed from the present open, uncontrolled area to a landfill where they will be contained in a more controlled manner and immobilized as long as the landfill cap and liner remain intact. Landfill maintenance is the responsibility of the company operating the facility. This alternative will require approximately two months to implement.

The possible health risks associated with this alternative include: the risk of accidental spills during transport to the landfill and the risks to populations near the landfill. While the risk of an accidental release during

transport is not quantified, this risk may be minimized by choosing a reputable trucking firm whose drivers exhibit safe driving records. The risks to populations living near landfills are considered by the operators of the facility and the federal and state regulatory agencies before the facility is constructed. These risks are minimized through design considerations. In addition, the licensing of a landfill by the regulatory agencies implies that the potential risks posed by a commercial landfill facility are minimal.

The costs associated with this alternative are:

- Capital \$1,844,365 and
- Annual O & M \$10,000.

Also included in the cost estimates are provisions for closing out the RI decontamination pad and plugging five of the RI monitoring wells. The final present worth of the off-site landfill alternative is \$2,017,285.

4.3 ALTERNATIVE 6 - EXCAVATION, STABILIZATION, AND OFF-SITE LANDFILL

The stabilization and off-site landfill alternative takes Alternative 4 one step further by adding stabilizing materials to the soil. This alternative offers immobilization but no destruction of the PCBs.

Figure 4-3 shows the proposed layout for the staging activities for implementation. The soils will be excavated beginning on the eastern portion of the site and stockpiled near the waste stabilization area. Wastes will be placed in the pug mill in the waste stabilization area and mixed with cement kiln dust before they are loaded into dump trailer trucks for transport to a chemical waste landfill in compliance with the Superfund Off-Site Disposal Policy.

The contaminated liquids will be collected and temporarily stored in a tank near the decontamination pad. The water will be added to the soil/cement kiln dust to aid the mixing and provide for the curing process. Dikes

000733

L-7

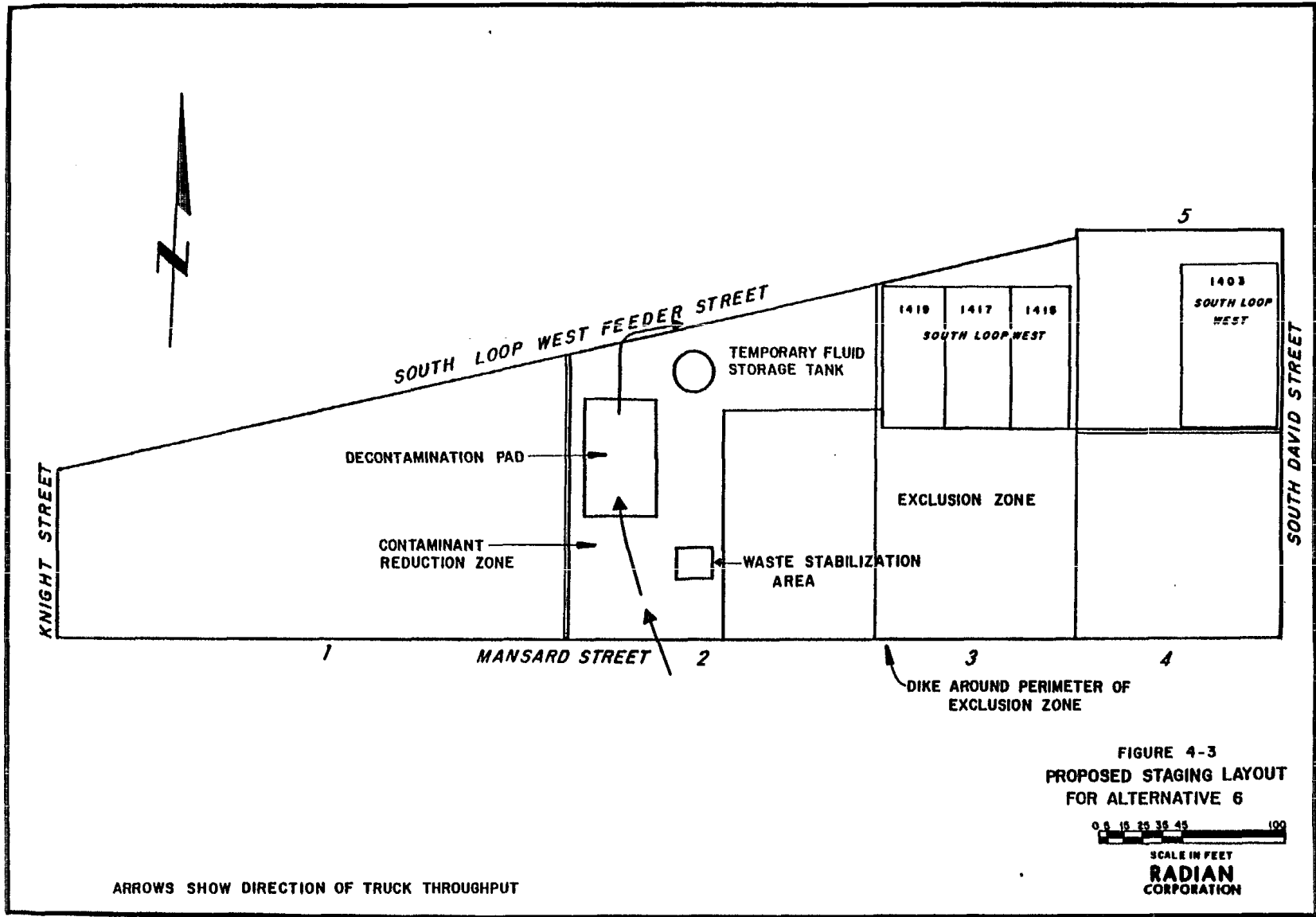

000734

will be constructed around the excavation perimeter to collect surface run-off during the excavation and solidification activities.

After the contaminated soils have been removed from the site, the decontamination pad will be dismantled and transported to the landfill for disposal. The excavation will be filled with topsoil placed in six inch lifts and then seeded with appropriate vegetation.

Long term monitoring would be required at the site after treatment to detect leaching. Monitoring would consist of collecting annual soil, water, and sediment samples.

While the stabilization and off-site landfill alternative does not reduce the toxicity of the contaminants, the PCEs will be removed from the present open, uncontrolled area to a landfill where they will be contained in a more controlled manner and immobilized as long as the stabilizing materials remain effective and the landfill cap and liner remain intact. Landfill maintenance is the responsibility of the company operating the facility. This alternative will require approximately four months to implement.

The possible health risks associated with this alternative include: the risk of accidental spills during transport to the landfill and the risks to populations near the landfill. While the risk of an accidental release during transport cannot be quantified, this risk may be minimized by choosing a reputable trucking firm whose drivers exhibit safe driving records. Furthermore, the stabilization process (while greatly increasing both the volume of materials to be landfilled and the number of truckloads to transport the materials) is thought to further reduce the possible health risk to the populations near the commercial landfill by adding greater immobilization potential.

The costs associated with this alternative are:

- Capital \$3,000,935 and
- Annual O & M \$10,000.

000735

Included in the cost estimates are provisions for closing out the RI decontamination pad and plugging five of the RI monitoring wells. The final present worth of the stabilization and off-site landfill alternative is \$3,173,855.

4.4 ALTERNATIVE 7 - EXCAVATION AND OFF-SITE INCINERATION

The off-site incinerator alternative, which destroys the PCBs through combustion, requires that the upper two feet soil in the most highly contaminated areas be excavated (as described in Section 3), transported, and incinerated at an off-site incinerator. Approximately 2500 cubic yards of soil will require excavation and transport 20 miles to an appropriate facility, necessitating over 168 dump trailer loads of about 17 cubic yards per load.

The proposed staging plan for this alternative is shown in Figure 4-2. The dump trailers will enter the site on the eastern side, receive a load of contaminated soils, drive through the decontamination pad, and once steam-cleaned, exit to the South Loop via Mansard and Knight Streets. Excavation will commence along the eastern edge of the site and progress westward.

Once excavation of the contaminated soils has been completed, the decontamination pad will be dismantled and transported to the landfill for disposal. The excavation will be filled with topsoil and then seeded with appropriate vegetation.

Long-term monitoring after remediation would still be required at the site. Monitoring would be accomplished by collecting soil, water, and sediment samples.

The cost associated with this alternative are:

- Capital \$5,665,660 and
- Annual O & M \$10,000.

000736

Included in the cost estimates are provisions for dismantling the RI decontamination pad and plugging five of the monitoring wells. The present worth of this alternative is \$5,838,580.

4.5 ALTERNATIVE 8 - EXCAVATION AND ON-SITE INCINERATION

The on-site incineration alternative requires that two feet of contaminated soil be excavated as described previously with water sprayed for dust control. This alternative fulfills the requirement for a destruction alternative as recommended by SARA. The soils will be stored temporarily in waste piles and then fed into an on-site incinerator equipped with emission controls and ash handling equipment. The incinerator exhaust gases will be scrubbed prior to venting to the atmosphere. The incinerator ash will be tested, and if reclassified, it will be backfilled into the excavation and possibly covered by a clay cap. Otherwise, the ash will be disposed in a hazardous waste landfill. The scrubber water will be treated by running through serial activated carbon columns, and the carbon will require incineration once spent. A shredder will be used to reduce lumps of clay, rocks, and other large debris to an acceptable size for incineration. Large pieces of debris, such as bricks, rocks, or concrete, found in the area to be excavated that cannot be shredded will be assumed to be PCB wastes and will be disposed at an off-site landfill specifically permitted for the disposal of PCBs and in compliance with Superfund Off-Site Disposal Policy. The decontamination pad will also be disposed at a landfill.

Figure 4-4 shows the proposed staging layout for implementing the on-site incineration alternative. Excavation will occur from east to west, and the soils will be fed directly into the incinerator hopper over a 40 to 50 day operation period. The ash will be stockpiled on the western end of the site. If the ash meets TCLP requirements, it will be backfilled in six inch lifts on-site into the excavation once the excavation and incineration have been completed. A cap may be required. Otherwise, the ash will be landfilled off-site.

000737

11-7

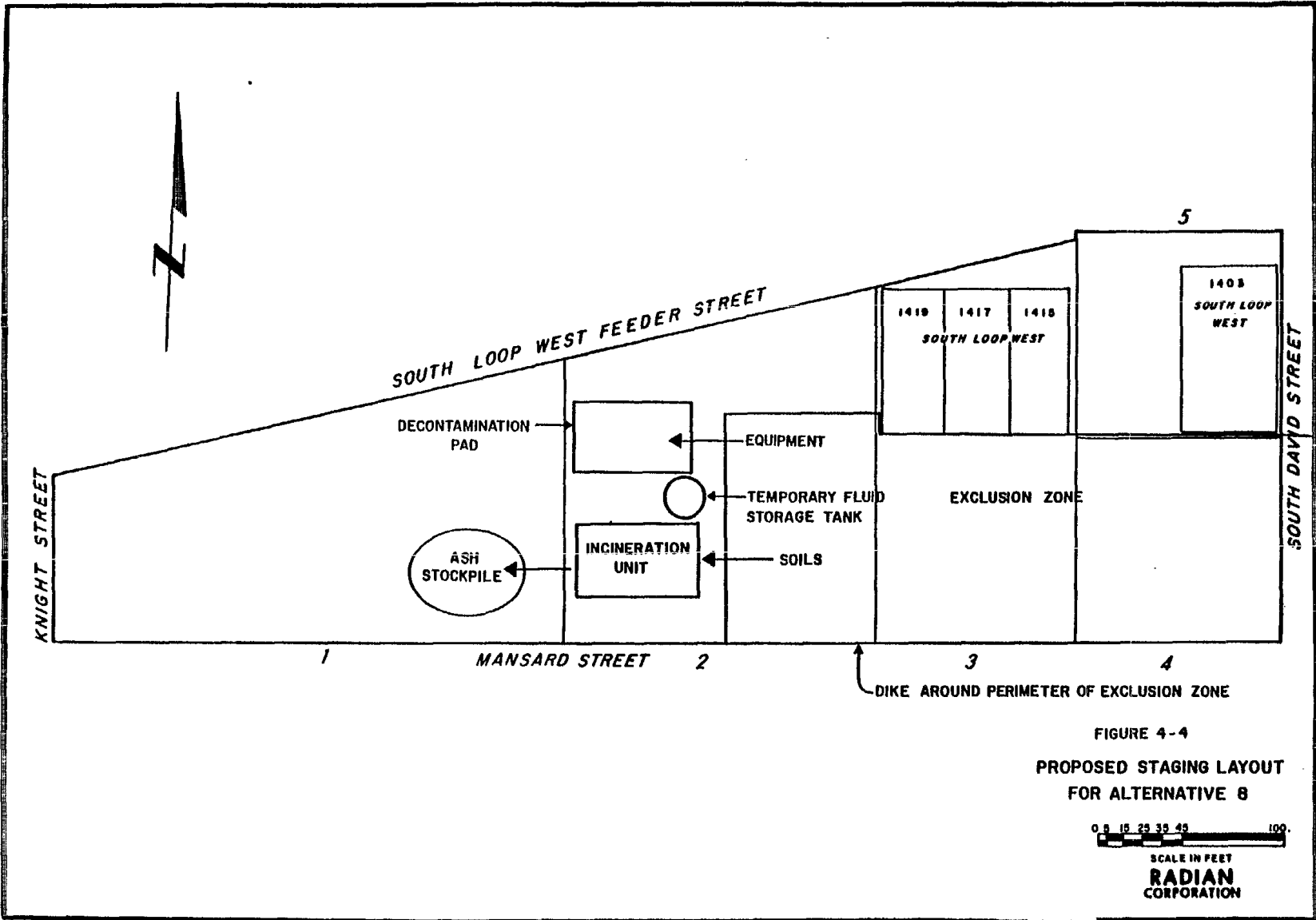

000738

Contaminated water, including rainfall run-off, water from decontamination processes, and incinerator wastewater, will be stored temporarily in a storage tank and treated. The run-off will be collected by a series of dikes approximately one foot high placed around the excavation boundaries.

The incinerator process heats the soils and water to a temperature of at least 1800°F, destroying the few remaining organics. The gases are cooled before entering the scrubber for final cleaning and then reheated by steam injection, and a demister removes the final moisture before release to the atmosphere. Figure 4-5 shows a typical, transportable incinerator unit.

The scrubber actually consists of a scrubbing device, clarifier, chemical feed equipment, and a circulating system. Water is used as the adsorbing medium, and lime is added to control the pH as needed. The clarifier removes any precipitate that may form. Clarifier effluent will be treated by passage through two activated carbon columns in series. Influent and effluent sampling will be maintained through chemical analyses to measure treatment efficiency. Once spent, the carbon will be incinerated and replaced with fresh activated carbon.

Water from the carbon columns shall be discharged to the nearby drainage ditch. While an NPDES permit need not be acquired, all effluent quality specifications of such a permit must be met before discharge may occur. Effluent quality will be determined by testing samples.

The on-site incineration alternative results in at least 99.9999% reduction of PCB contamination in the excavated soils by destroying the contaminants (Ogden Environmental Services, 1987). Even so, long term monitoring after remediation would still be required at the site. Monitoring would include soil, water, and sediment samples.

The costs associated with this alternative are:

- Capital \$1,983,766
- Annual O & M \$10,000, and
- Test Burn \$35,000.

000739

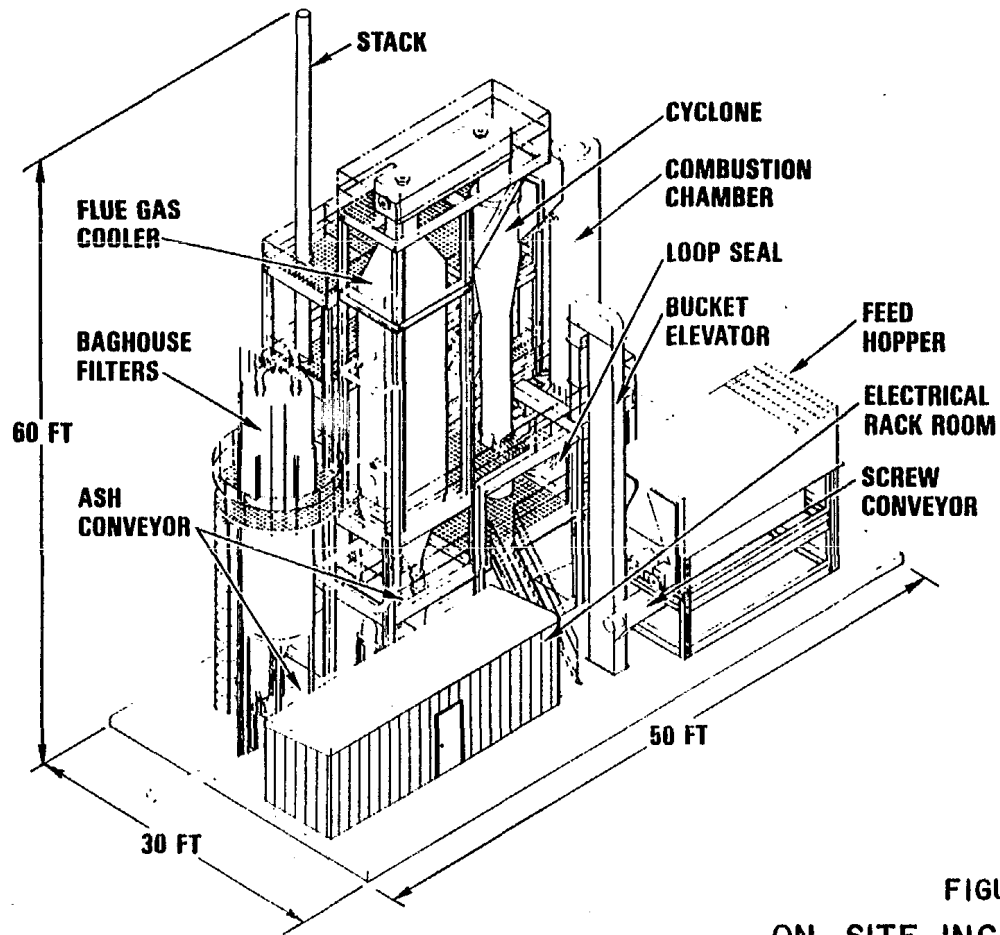

FIGURE 4-5
ON-SITE INCINERATION UNIT

RADIAN
CORPORATION

SOURCE: OGDEN ENVIRONMENTAL SERVICES, 1987

000740

The test burn consists of shipping four to five 55-gallon drums containing representative waste samples to the incinerator vendor. The test will last 8 to 10 hours, and will finalize the costs and treatability of the waste with the method in addition to securing agency approval. The cost estimates include provisions for dismantling the RI decontamination pad and plugging five of the monitoring wells plus a five year review. The present worth of the alternative is \$2,156,686.

4.6 ALTERNATIVE 10 - EXCAVATION AND ACTIVATED SLUDGE TREATMENT

The activated sludge alternative requires that the two feet of contaminated soil be excavated as described previously. Dust control measures will also be employed. If successful, this alternative provides for destruction of the PCBs.

Figure 4-4 depicts a proposed staging layout for implementing this alternative (substituting a bioreactor for the incinerator and stockpiled soils instead of stockpiled ash). Soil excavation will begin on the eastern portion of the site and progress westward. The soils will be loaded into the activated sludge unit in batches with water collected in the temporary storage tank and/or a microbiological slurry. The soils will then be treated, dewatered, tested, and stockpiled once the PCBs have biodegraded to the 25 ppm PCBs cleanup level. Sludges not meeting the cleanup level are recycled through the bioreactor. This process is shown schematically in Figure 4-6.

Contaminated water, including rainfall run-off and decontamination fluids, will be stored temporarily in the storage tank and treated in the bioreactor. Rainfall run-off collection will be facilitated by a series of dikes approximately one foot high placed around the excavation boundaries. Once treated, it will be tested to meet NPDES requirements and discharged.

The activated sludge process employs a variety of microorganisms to consume the PCBs in a slurry medium. Mechanical or diffused air aeration supplies oxygen to the microbes. An engineering scale test begun in September,

000741

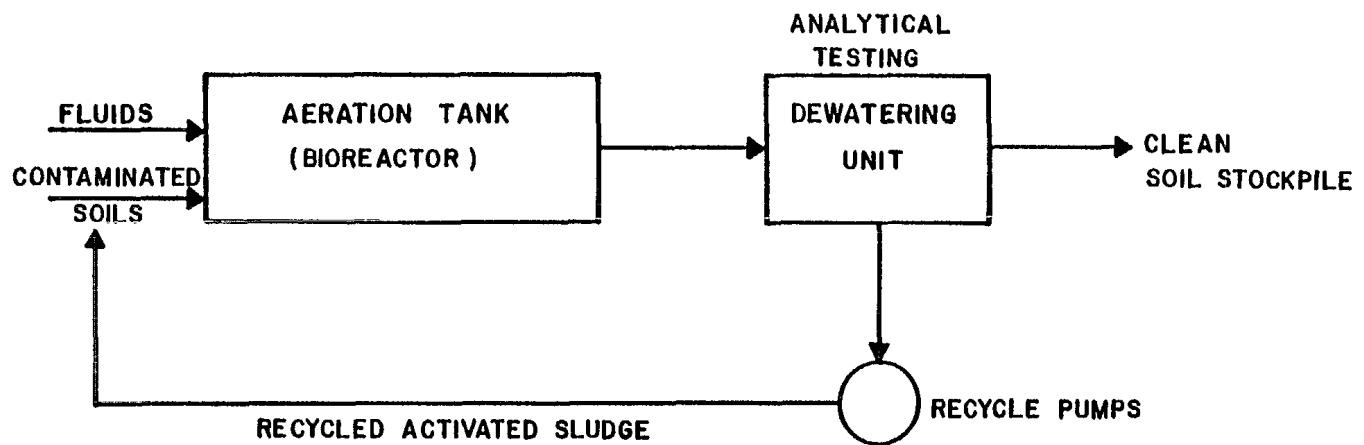

SOURCE: REYNOLDS, 1982

FIGURE 4 - 6
ACTIVATED SLUDGE PROCESS
FLOW DIAGRAM

RADIAN
CORPORATION

000742

1983, showed systematic reductions in PCB levels from 2000 ppm in sludge wastes and 44 and 29 ppm in the aqueous wastes to 4 ppm overall by January, 1984 (DeTox, 1987).

The costs associated with the alternative are:

- Capital \$2,889,637,
- Annual O & M \$10,000, and
- Pilot Scale Test \$20,000.

These costs include provisions for dismantling the RI facilities and 5 year reviews. The pilot scale test will be performed on-site on a 55-gallon sample of representative waste. The test will require 2 to 4 months. The total present worth is \$3,062,557.

4.7 **ALTERNATIVE 11 - EXCAVATION AND CONTAINED LANDFARM**

The contained landfarm alternative requires that the two feet of contaminated soil be excavated as described previously and placed into a contained landfarm.

This alternative will be implemented in stages. Figure 4-7 shows the proposed staging diagram. The contaminated soils will be excavated from Area 4 and stockpiled temporarily in Area 2. An additional four feet of clean soil will be excavated in the landfarm area (contaminated soils will be treated in this excavation). A dike will be built using this soil around both the landfarm area and the area to be remediated, or exclusion zone. The dikes will be approximately one foot above ground surface with a top width of 0.5 feet and a bottom width of 2.5 feet. The landfarm area and landfarm dikes will be covered with welded, HDPE, which in turn will be covered by six inches of clean soil to anchor the liner in place and prevent the tilling equipment from tearing it.

000743

4-17

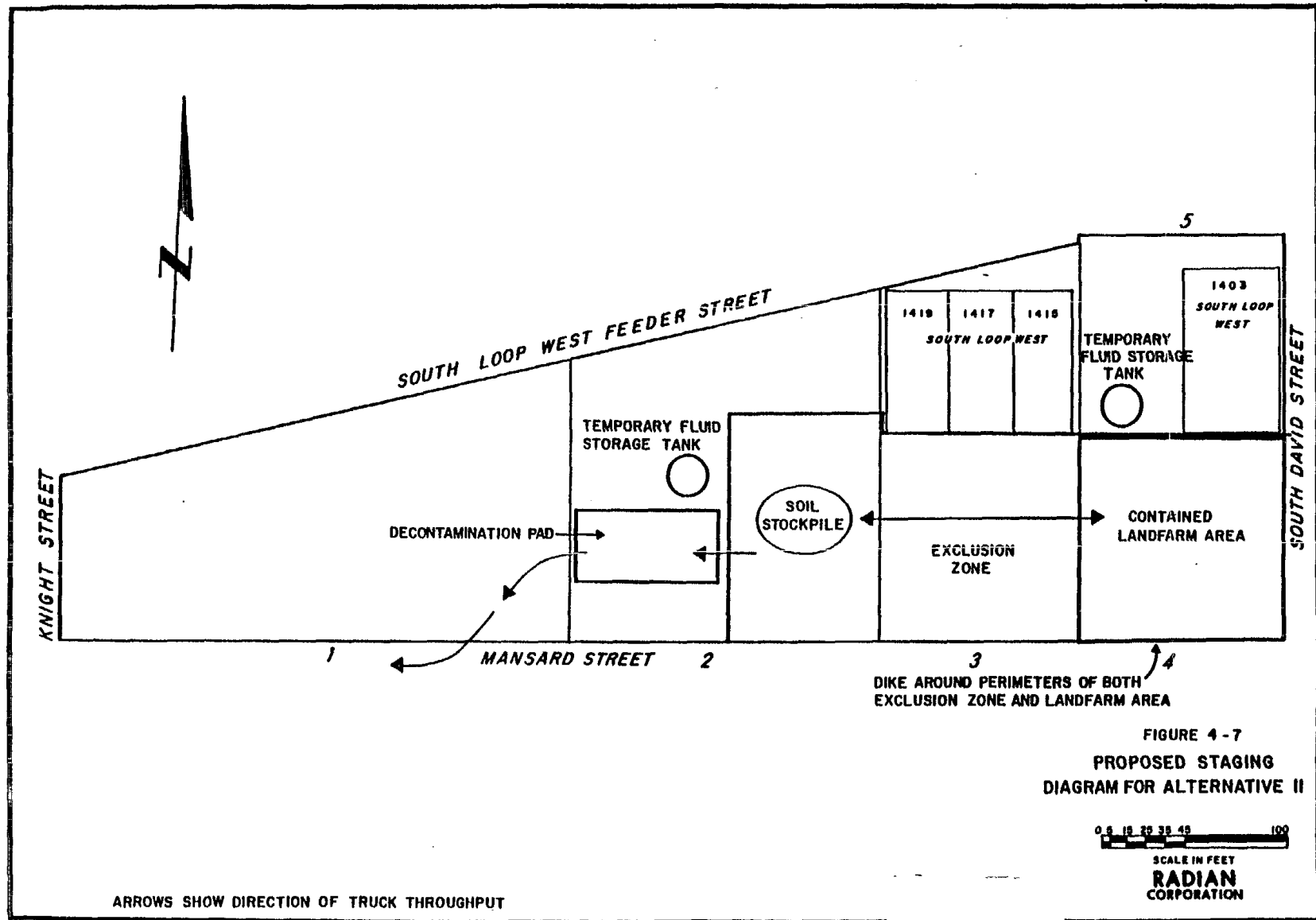

FIGURE 4-7
 PROPOSED STAGING
 DIAGRAM FOR ALTERNATIVE II



SCALE IN FEET
RADIAN
 CORPORATION

ARROWS SHOW DIRECTION OF TRUCK THROUGHPUT

000744

Treatment will commence with evenly spreading 6 to 8 inches of contaminated soils in the landfarm area. The landfarm soils will be sprayed with acclimated microbes and tilled on a regular bases to expose the microbes to oxygen to enhance the PCB biodegradation rate. Biphenyl may be sprayed on the soils to further enhance th biodegradation rate (Brunner, et al. 1985). Once testing shows the soils have attained the 25 ppm PCB cleanup level, the next layer of soil will be placed in the landfarm, and the whole process is repeated. Once all the soils have attained the 25 ppm PCBs cleanup level, the treated soils will be subjected to a TCLP test. If the treated soils meet the specifications of the TCLP test, the soils may be reclassified as nonhazardous, revegetated, and left in place. Otherwise, they will require landfilling or capping.

The time required for implementation of this alternative is on the order of eight months to one year.

The costs associated with this alternative are:

- Capital \$2,148,126,
- Annual O & M \$10,000, and
- Pilot Scale Test \$20,000.

The pilot scale test will be similar to that of the activated sludge alternative. The total cost or present worth is \$2,321,046.

4.8 ALTERNATIVE 12 - EXCAVATION AND CHEMICAL TREATMENT

This innovative treatment results in the dechlorination of PCBs by applying alkali metal polyethylene glycolates (APEG) to the soil yielding arylpolyglycol byproducts that are nontoxic as determined by toxicological tests. The mechanisms of the chemical reaction follow. First, an alkali metal hydroxide such a potassium hydroxide (KOH) is reacted with an alcohol or glycol to form an alkoxide. The alkoxide reacts with a chlorine atom on the PCB to yield an ether and an alkali metal salt. These reactions occur until the PCBs have been completely dechlorinated. The removal of just one chlorine molecule

converts the reaction products into a less toxic, more soluble form (Rogers, et al., 1987).

Figure 4-4 shows a staging diagram similar to that required for the chemical treatment alternative; however, the incineration unit and ash stockpile should read reactor and clean soil stockpile, respectively. Soils will be placed into the reactor, treated with APEG, and then stockpiled for later use as backfill into the excavation. Chemical analyses will be used to determine that the 25 ppm PCB cleanup limit has been met and for reclassifying the treated soils.

Decontamination pad materials and disposable clothing will be containerized, transported, and disposed at an off-site landfill specifically permitted for the disposal of PCBs and in compliance with Superfund Off-Site Disposal Policy.

Water tends to inhibit the dechlorination procedure. Therefore, dikes will be built around the portion of the site to be remediated. The dikes will prevent run-on from entering the site (and to keep the soils drier) and will aid in the collection of run-off from within the dikes for temporary storage in a tank before treatment, if required, and discharge or disposal.

Chemical treatment changes the chemical composition of the PCBs by removing chlorine molecules. Using sodium polyethylene glycolate (NaPEG) for the process produces polyhydroxylated biphenyls and hydroxy-benzenes (Sworzyn and Ackerman, 1981). In addition, the process evolves large amounts of sodium chloride (salt) (Sworzyn and Ackerman, 1981). The sodium chloride should not create any particular disposal problem.

Precise destruction efficiencies have not yet been determined. The treatment of the soils in the reactor with APEG will continue until the PCB

levels are less than 25 ppm, which will be determined by periodic sampling and laboratory analyses. A pilot scale test will be required prior to full scale implementation. Even though the PCBs are destroyed with this method, long term monitoring in the form of soil, water, and sediment samples will be required.

The costs associated with this alternative are:

- Capital \$1,789,414,
- Annual O & M \$10,000, and
- Pilot Scale Test \$20,000.

The pilot scale test will be performed on a 55-gallon representative sample of the waste for a ten hour test. These costs include provisions for dismantling the RI decontamination pad and plugging five of the monitoring wells plus a five year review. The total present worth of this alternative is \$1,962,334.

4.9 ALTERNATIVE 15 - IN SITU GLASSIFICATION

In situ glassification is an innovative treatment process for destroying organic contaminants and providing long term immobilization of inorganic contaminants. The process has been developed by scientists at Battelle's Pacific Northwest Laboratory.

The process operates in the following manner. A square array of four electrodes is placed in the soil to the desired treatment depth, at least two feet in this case. A mixture of graphite and glass frit is spread between the electrodes to act as a starter path for the electrical current established by the potential applied to the electrodes. The current heats the starter path and adjacent soils to 3600^oF, well above the normal melting temperatures (2000 to 2500^oF) of most soils. The molten soil becomes conductive, carrying the electric current to non-molten soil and melting it, incorporating the inorganic constituents and pyrolyzing the organic ones. The pyrolysis byproducts migrate to the surface and combust in the presence of oxygen, and the hood placed over the treatment area collects the gases for treatment. An example application is shown in Figure 4-8.

000747

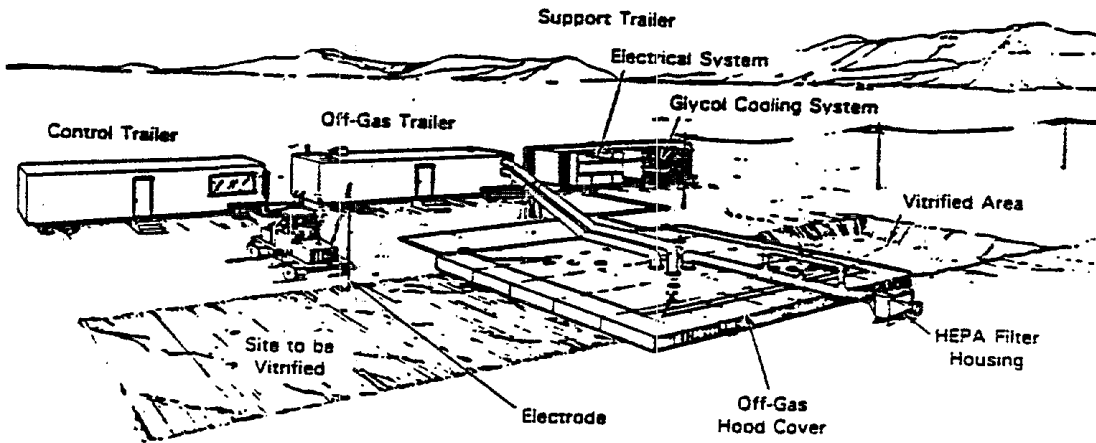

000748

FIGURE 4 - 8
 APPLICATION OF THE
 IN SITU GLASSIFICATION
 PROCESS TO A GENERIC SITE

RADIAN
 CORPORATION

SOURCE: FITZPATRICK, et al., 1986

The specially designed hood allows the collection of gases generated during the glassification process while maintaining a controlled atmosphere in which the gases may combust. The gases from the off-gas hood pass into the off-gas trailer (schematically represented in Figure 4-9) where they pass through a gas cooler, two wet scrubber systems, two heat exchangers, two process scrub tanks, two scrub solution pumps, a condenser, three mist eliminators, a heater, a charcoal filter assembly, and finally to a blower system and the atmosphere (Fitzpatrick, et al., 1986). A major support component of the off-gas system is the glycol cooling system which removes the heat build-up in the off-gas treatment system resulting from cooling the off-gases. The heat is vented to the atmosphere by way of a fin tube, air cooled heat exchanger.

The vitrification process encompasses five subsystems for complete treatment: (1) electrical power supply, (2) off-gas hood, (3) off-gas treatment, (4) off-gas support, and (5) process control. Electricity can be obtained from generators or power lines. Three transportable trailers are used to house the control equipment. The off-gas trailer contains equipment to cool, scrub, and filter the gases collected in the hood.

The processing rate progresses at three to five cubic yards per hour. A crane is required to move the hood and to assist with off-gas line coupling. Moving the equipment from one location to another generally takes 16 hours. Assuming an electrode spacing such that the treatment area forms a 28 feet by 28 feet treated block and a processing rate of three cubic yards per hours, treating the surface and shallow subsurface soils at ITS would require the electrodes to be placed 43 times (at 16 hours per setup) for a total of 690 hours placement time. Actual treatment time would be approximately 835 hours. The total time would be 1525 hours, or 64 days.

The forty-three successful bench, engineering, and pilot scale tests performed to date indicate that treatment depths to fifty feet are possible (Fitzpatrick, et al., 1986). Lab tests show vitrification will work for virtually any soil type; the high temperatures melt the soil particles completely

000749

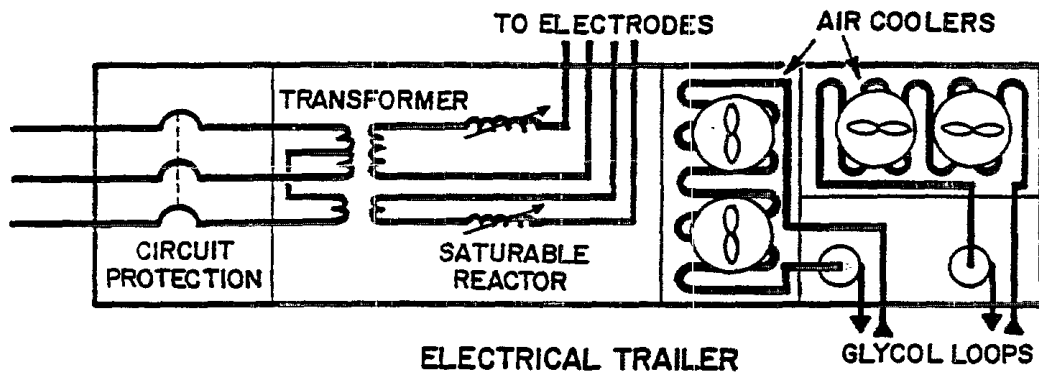

ELECTRICAL TRAILER

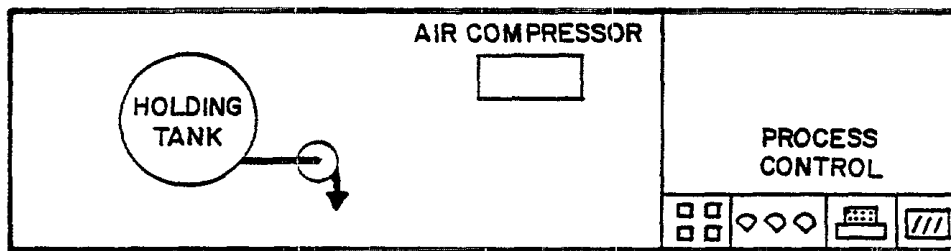

PROCESS CONTROL TRAILER

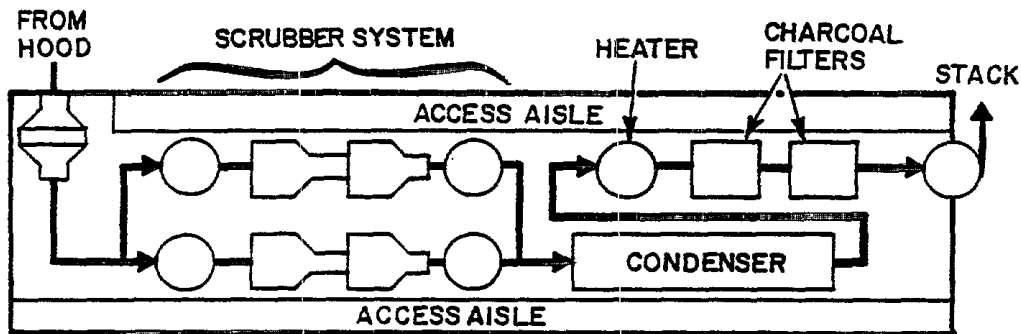

OFF-GAS TRAILER

FIGURE 4-9
 PROCESS TRAILERS FOR THE
 LARGE SCALE IN SITU
 GLASSIFICATION UNIT
RADIAN
 CORPORATION

SOURCE: FITZPATRICK, et al.,
 1986

000750

and do not cause cracks to form in clay soils. Buried drums and saturated soils may also be vitrified. The volume change experienced with this method as the air in the soil void spaces is forced out may contribute to nearby building foundation problems. The process is currently being applied at a site to vitrify only the surface soils with ground remediation to occur at a later date with another alternative.

Logistical requirements for the vitrification equipment are few. The site will require brush clearing to enable maneuverability of the three trailers and off-gas hood and to make electrode insertion easier. Electricity is already available on-site so generators will not be required. Surface water controls will be used at the ITS site with this alternative, and both collected surface water and scrub water from the off-gas treatment system will require storage in a temporary tank, testing, and discharge or disposal at a deep well injection facility. A pilot scale test is recommended prior to full scale implementation.

The in situ vitrification process removes the potential threats to public and environmental health by destroying the PCBs in the soil with a destruction efficiency of greater than 99.9999%. Any remaining contaminants in the soils are immobilized for periods of time greater than one million years. Vitrified soils have been tested for PCBs and degradation products of PCBs such as dioxins and furans. These compounds were not detected. Workers are protected in at least two ways: 1) extensive excavation will not occur with this alternative so fugitive dust contaminated with PCBs is less of a problem, and 2) the off-gas hood system collects and the all emissions produced during the vitrification process.

Other advantages of the vitrification process include the applicability of the process to a variety of soils and protection of the workers from the contaminant. In addition, because the method is applicable to saturated soils also, this alternative represents a potential treatment means for the deeper soils at the ITS site contaminated with TCE.

Even though the glassification process is energy intensive, the process does offer cost effectiveness (\$100 to \$250 per ton) for PCB destruction. The costs associated with this alternative are:

- Capital costs \$1,027,970,
- Annual O & M \$10,000, and
- Pilot Scale Test \$25,000.

The pilot scale test will consist of laboratory tests on a representative sample of approximately ten kilograms. The total present worth of this alternative is \$1,200,890.

000752

000753

FOR NUMBERING PURPOSES, THIS PAGE IS BLANK

SECTION 5
DETAILED EVALUATION OF ALTERNATIVES

This section provides a detailed evaluation of the alternatives which passed the screening process outlined in the previous section. The evaluation for each alternative will address:

- Technical Analysis,
- Institutional Requirements Analysis,
- Public Health Analysis,
- Environmental Impact Analysis, and
- Cost Analysis.

This evaluation allows direct comparison between alternatives. Various criteria are used for this detailed evaluation of alternatives. The technical analyses address the performance, reliability, implementability, and safety of each alternative in greater depth. The institutional analysis discusses each alternative's attainment of applicable or relevant environment and health standards. The public health analysis documents that the remedial alternative minimizes the long-term effects of any residual contamination and protects the public during and after implementing the alternative. The environmental impact analysis determines the existence of any adverse environmental effects of the alternatives and methods for mitigating these effects. Finally, the detailed cost analysis encompasses an estimation of capital and operation/maintenance costs for the remedial alternatives, a tabulation of the present worth of the alternative in terms of 1987 dollars, a sensitivity analysis of the cost analysis to changes in key parameters, and a summary of the evaluation data for use in selecting a remedial alternative.

A rating system is employed to express the extent to which each alternative meets the criteria for each of the evaluation categories. Alternatives are rated either high, moderate or low.

- A high rating for a particular criterion denotes that the alternative meets or exceeds the remedial objectives.
- A moderate rating denotes that the remedial alternative meets a portion but not all of the remedial objectives.
- A low rating for a criterion denotes that the remedial alternative does not meet the remedial objectives.

5.1 TECHNICAL ANALYSIS

This section presents a detailed technical evaluation with respect to the performance, reliability, implementability, and safety of each alternative.

The performance of an alternative is determined by two criteria: the effectiveness of the alternative to perform the intended functions of contaminant diversion, removal, destruction, or treatment and the useful life of the alternative. The effectiveness refers to the degree of protection an alternative affords in preventing or minimizing danger to public health or the environment. The effectiveness of an on-site alternative is affected by locational factors such as aquifer classification, site geology, and floodplain impacts. The useful life of the alternative addresses the deterioration with time of remedial actions such as capping and immobilization; therefore, each alternative should be evaluated in terms of the projected life of each of the component technologies.

The reliability of a remedial action may be evaluated in terms of the operation/maintenance requirements plus the demonstrated performance at similar sites. Evaluations of the operation/maintenance requirements for the alternatives should address the availability of labor, materials, and their associated costs, in addition to the frequency and complexity of the operation and maintenance activities. The demonstrated performance evaluation will give preference to those alternatives proven effective under conditions similar to those located at the site. In addition, an estimate of the probability of failure will be made in either quantitative or qualitative terms.

The implementability of an alternative considers issues such as constructability and the time required to achieve the desired level of remedial response. The constructability, or ease of installation of the alternative, is dependent on site conditions, the availability of off-site disposal sites and equipment, and even public acceptance of a particular alternative. Because exposure to hazardous substances should be quickly eliminated, the time to implement an alternative and the time to achieve the desired level of cleanup, must be considered.

The fourth issue regarding the technical analysis is safety. Each alternative will be evaluated with regard to long and short-term threats to the safety of nearby communities and environments as well as the safety of the workers during implementation. While each alternative leaves behind residual amounts of PCBs at concentrations less than 25 ppm, these residual PCBs do not present a significant health risk. Furthermore, for all alternatives, the site will receive a five year review, and at that time, groundwater samples will be collected. In addition, the site will be monitored annually for each alternative, with the annual monitoring consisting of surface water and groundwater samples plus soil and sediment samples.

The final issue regarding the technical evaluation is an overall technical rating. This evaluation was reached by assigning a value of "1" to a low rating, "2" to a moderate rating, and "3" to a high rating. When the rating ranges over two or three values, an average is taken over that range. The separate ratings for performance, reliability, implementability, and safety were then averaged together to obtain a final rating for the technical analysis.

A tabulation of the technical analysis ratings is shown in Table 5-1.

TABLE 5-1

SUMMARY OF TECHNICAL FEASIBILITY EVALUATION

Alternative	Performance	Reliability	Implementability	Safety	Overall Technical Feasibility
1. No Action	Low	Low	High	Low	Low
4. Excavation and Off-Site Landfill	High	Low	High	High	High
6. Excavation, Stabilization, and Off-Site Landfill	High	Low	High	High	High
7. Excavation and Off-Site Incineration	High	High	Moderate	High	High
8. Excavation and On-Site Incineration	High	High	Moderate	High	High
10. Excavation and Activated Sludge Treatment	High	Moderate*	Low	High	Moderate*
11. Excavation and Contained Landfarm	High	Moderate*	Low	High	Moderate*
12. Excavation and Chemical Treatment	Moderate	High*	Moderate	High	Moderate*
15. In Situ Glassification	High	High*	Low	High	High*

* Rating may change should a pilot study prove the alternative effective at the IIS site.

000757

5.1.1 Alternative 1 - No Action

The no action alternative encompasses no remedial actions besides long-term monitoring to detect contaminant migration.

Performance - The no action alternative provides no additional control of contaminant migration and provides no control of exposure of contaminants to the nearby populations.

The performance rating for the no action alternative is low.

Reliability - This alternative has extensive monitoring activities associated with it. In addition, this alternative has not demonstrated an effective performance.

Therefore, the reliability rating for the no action alternative is low.

Implementability - The actions associated with this alternative are easily implemented.

The implementability rating for the no action alternative is high.

Safety - This alternative does not provide additional safety in the long or short term.

The safety rating for the no action alternative is low, and therefore, the overall technical rating is low.

5.1.2 Alternative 4 - Excavation and Off-Site Landfill

The off-site landfill alternative combines on-site removal with transport to an off-site landfill in compliance with Superfund Off-Site Policy. This alternative immobilizes but does not destroy the contaminants.

Performance - The performance of this alternative is governed by the effectiveness and the useful life of the alternative and the effectiveness of the component technologies. Contaminated soils will be excavated using conventional earthwork equipment. Additional sampling will determine the existence of hot spots requiring further excavation. While the landfill cap and liner prevent rainfall percolation and subsequent leachate generation, the cap and liner will deteriorate with time. Also, the transport technology must be considered. While transport adds some measure of risk due to the possibility of an accident and subsequent release, the transport and removal technologies are effective means of controlling contaminated soils. However, the effectiveness and the useful life of a landfill are finite.

The performance of the off-site landfill alternative is rated high.

Reliability - The reliability of this alternative depends on operation/maintenance requirements and the demonstrated performance of the alternative. Landfill designs now include durable, chemical resistant synthetic liners and leak detection monitoring systems. While synthetic materials do deteriorate with time, HDPE is compatible with contaminants at the site and should remain intact for at least 30 years.

The landfill reliability also depends on the maintenance of the facilities. This, however, is the responsibility of the off-site landfill operator. In addition, compliant landfills accepting PCB wastes must meet the requirements for design, construction, monitoring, and maintenance as specified in 40 CFR 761.75. No additional operation or maintenance will be required on-site. Landfills have been proven both effective and ineffective in their reliability, depending on a number of factors such as geology, type of waste, and landfill design.

The reliability of the off-site landfill alternative is determined to be low because the landfill liner will eventually fail.

000759

Implementability - The constructability and time required for the implementation of the off-site landfill alternative are acceptable. Removal and transportation techniques are easily implemented, proven, and will require approximately one month for completion unless the site experiences inclement weather.

The implementability of the off-site landfill alternative is rated high.

Safety - Safety issues concern both the long and short term. Long term exposure is alleviated at the site by removal of the contaminants. However, while the contaminants are placed in a secure, commercial landfill, they are only immobilized, and potential for exposure in the long term exists at the landfill site. Even so, landfills are an acceptable method to effectively dispose of contaminated soils. Short term exposure is mitigated by the use of PPE and proper decontamination procedures.

The safety of the off-site landfill alternative is rated high. The overall evaluation is rated high.

5.1.3 Alternative 6 - Excavation, Stabilization, and Off-Site Landfill

The off-site landfill alternative combines on-site removal with stabilization prior to transport to an off-site landfill in compliance with Superfund Off-Site Policy. This alternative immobilizes but does not destroy the PCBs.

Performance - The performance of this alternative is governed by the effectiveness and useful life of both the off-site landfill and the stabilizing materials. The transport portion of the alternative adds some measure of risk due to the possibility of an accident and subsequent release, but choosing a responsible contractor minimizes these risks. The transport and removal technologies are effective means of controlling contaminated soils. The stabilizing materials will contribute to minimize leachate generation. However, as

discussed for the excavation and off-site landfill alternative, the effectiveness and useful life of a landfill are finite.

The performance of this alternative is rated high.

Reliability - The reliability of this alternative depends on operation/maintenance requirements and the demonstrated performance of the alternative. These items are discussed under Alternative 4 - Excavation and Off-Site Landfill.

The reliability of this alternative is low.

Implementability - The constructability and time required for the implementation of this alternative are acceptable. Removal and transportation techniques are easily implemented, proven, and will require approximately two months to implement in conjunction with the stabilization.

The implementability of this alternative is rated high.

Safety - The same safety issues discussed for the off-site landfill alternative apply to this alternative. Landfills are an acceptable method to effectively dispose of PCB-contaminated soils. The stabilization step adds additional immobilization capabilities to the PCBs.

Therefore, the safety of the stabilization and off-site landfill alternative is rated high. The overall evaluation is rated high.

5.1.4 Alternative 7 - Excavation and Off-Site Incineration

The off-site incineration alternative includes excavating the contaminated soils and transporting them off-site to a compliant incinerator.

Performance - Performance involves the effectiveness and useful life of the alternative. Removal is an effective means of negating the health threat at the ITS site. Incineration is extremely effective in reducing PCB concentrations by destroying them, resulting in an infinite useful life. Federal regulations require a DRE of at least 99.9999%; however, many incinerator types actually show an even greater DRE.

The performance for the off-site incineration alternative is high.

Reliability - Reliability includes issues such as the operation and maintenance requirements and the demonstrated performance of the alternative. Incineration has been shown in numerous demonstrations to destroy PCBs. Once the PCBs have been destroyed, the health threat no longer exists.

The alternative exhibits a high reliability rating.

Implementability - The degree of implementability of this alternative involves both the ease of implementation and the time required for the remedial actions to be completed. The excavation and transport of the soils rely on proven techniques. The difficulty in implementing the off-site incineration alternative is locating an incineration facility in compliance with Superfund Off-Site Disposal Policy.

The implementability of the off-site incineration alternative is moderate.

Safety - Safety issues include both long and short term public health exposures. PPE and proper waste handling methods increase worker safety for the short term. Transporting the contaminated soils by a reliable carrier under DOT rules will minimize accidental releases during transport. Controlled burning environments and well maintained scrubbers will prevent harmful air emissions at the incinerator site.

The safety rating for this alternative is high, and the overall technical evaluation for the off-site incineration is high.

5.1.5 Alternative 8 - Excavation and On-Site Incineration

The on-site incineration alternative includes constructing an incinerator on-site, excavating the contaminated soils, and incinerating the soils.

Performance - Performance involves the effectiveness and useful life of the alternative. Incineration is extremely effective in reducing PCB concentrations. In fact, federal regulations require a DRE of at least 99.9999% and, as discussed, many incinerator types actually show an even greater DRE. This alternative provides for destruction of the contaminants. Therefore, this alternative presents an infinite useful life.

The performance rating for the on-site incineration alternative is high.

Reliability - Reliability includes issues such as the operation/maintenance requirements and the demonstrated performance of the alternative. Since incineration has been shown in numerous demonstrations to destroy PCBs, once the PCBs have been destroyed, the health threat no longer exists.

The on-site incineration alternative exhibits a high reliability rating.

Implementability - The degree of implementability of this alternative involves both the constructability and the time required for the remedial actions to be completed. The incinerator is built on-site using proven construction methods. In addition, ample space exists on-site for the incinerator. However, availability of the incinerator equipment may be limited.

The implementability of the on-site incineration alternative is rated moderate.

Safety - Safety issues for this alternative include both long and short term exposure. PPE and proper waste handling methods increase worker

safety for the short term. While the incinerator destroys the contaminants in the soils, negating any threat to the nearby populations, incinerators have been shown to emit dioxins and furans. The new health threat is minimized by controlling the combustion process to destroy dioxins and furans. High temperatures, sufficient oxygen, and long enough dwell times have been found to almost completely destroy the PCBs and combustion products, and these parameters are clearly addressed and specified in 40 CFR 761.70. With the controls on air emissions, incinerators present an effective, safe alternative for remediating soils contaminated with PCBs.

The safety rating for this alternative is high. The overall technical evaluation for the on-site incineration alternative is high.

5.1.6 Alternative 10 - Excavation and Activated Sludge Treatment

The activated sludge alternative includes excavating the soils and reacting them in a bioreactor with microorganisms which consume the PCBs as a carbon source producing carbon dioxide and water.

Performance - The performance of this alternative is rated by two criteria: effectiveness and useful life. While data supporting the effectiveness of this alternative is difficult to obtain (it is all proprietary), at least one vendor has shown success in implementing this alternative (DeTox, 1987). In addition, once the soils have been bioremediated, the health threat is removed, and the alternative presents an infinite useful life.

The performance rates high for this alternative.

Reliability - Reliability includes issues such as operation/maintenance requirements and the demonstrated performance of the alternative. Even though the bioremediation destroys the PCBs, annual monitoring will be performed at the site to monitor the remediated soils. In addition, a five year

evaluation of the groundwater is planned. No other operation and maintenance is required. The demonstrated performance consists of two tests on PCBs in bioreactors. Both tests resulted in biodegradation of PCBs to substantially below the 25 ppm cleanup level. A treatability study is recommended prior to full-scale implementation.

The reliability of this alternative is moderate, pending the results of a pilot scale treatability study.

Implementability - The implementability of this alternative involves the constructability and time required for the remedial actions to be completed. The excavation technologies are well proven, and the biological technologies are readily implemented. The time required is another matter. While this alternative will require less implementation time than landfarming or in situ bioremediation due to the better mixing qualities of the microbes, nutrients, and oxygen, the implementation time will still require 4 to 6 months for a treatability study and as least as many months for full scale application.

Therefore, this alternative receives a low rating for implementability.

Safety - Safety includes both long and short term issues. PPE and proper waste handling procedures increase worker safety in the short term. The destruction of the PCBs through the metabolic actions of the microorganisms contributes to increased, long term safety.

The safety rating for this alternative is high. The overall technical evaluation for activated sludge is moderate.

5.1.7 Alternative 11 - Excavation and Contained Landfarm

The excavation and contained landfarm alternative encompasses excavating the soils to be remediated and bioremediating them in a lined area. The

soils are biodegraded by the soil microorganisms. Tilling is utilized to provide additional oxygen to the microorganisms, enhancing the process.

Performance - Performance considers the effectiveness and useful life of the alternative. Griffin, et al. (1978) have shown landfarming to be an effective means of remediating soils contaminated with PCBs. Because this alternative provides for destruction of the contaminants, the useful life of this alternative is infinite.

The performance of the landfarm alternative is high.

Reliability - Reliability discusses issues of operation/maintenance requirements and demonstrated performance of the alternative. Once the soils have been bioremediated, this alternative requires little in the way of operation/maintenance activities. As far as previously demonstrated performance is concerned, very little data exists, but the little that does exist exhibits great potential for this alternative.

The performance rating for this alternative is moderate.

Implementability - Implementability includes the ease of construction and the implementation time of the alternative. The construction methods are well proven, and the landfarming techniques are also well proven by the oil industry. However, implementation time is excessive. At least 4 to 6 months will be required for a treatability study. Another 8 to 12 months will be required for the full scale implementation.

Therefore, the implementability of this alternative is low.

Safety - Safety issues cover both short and long term potential exposures. Short term safety is enhanced through the use of PPE and proper waste handling procedures. Long term safety is greater enhanced because the PCBs are destroyed as they are consumed by the microorganisms.

This alternative receives a high safety rating and a moderate overall technical rating.

5.1.8 Alternative 12 - Excavation and Chemical Treatment

Chemical treatment includes the excavation of the contaminated soils and the application of an APEG solution to the soil to dechlorinate the PCBs rendering them less harmful.

Performance - The performance of this alternative may be rated by two criteria: effectiveness and useful life. The effectiveness of this alternative ranges from complete treatment of PCBs to almost no treatment of PCBs. Water has been proven to be an inhibitor of the dechlorination process; therefore, the effectiveness of this method may be limited in wet or humid climates. However, using an enclosed reactor vessel, such as a cement mixer or specially designed reactor, will enable the bypassing of this limitation. Once the PCBs are dechlorinated, this alternative results in an infinite useful life.

The performance of the chemical treatment alternative is rated moderate.

Reliability - Reliability of an alternative is measured by the operation/maintenance requirements and the demonstrated performance of the alternative. Once treatment has been completed and the treated soils are reclassified, then only annual operation/maintenance activities will be required. Laboratory investigation on soils contaminated with 1000 ppm PCBs show a reduction to less than 50 ppm by direct chemical treatment. Additional laboratory tests on similar, highly chlorinated compounds such as polychlorinated dibenzo-p-dioxins (PCDDs) and polychlorinated dibenzofurans (PCDFs) also show promise; all PCDD and PCDF was destroyed by potassium polyethylene glycolate (KPEG) when the sample was heated to 100°C. Most of the contaminants were destroyed at 70°C. Table 5-2 summarizes the results of the previous lab tests.

000767

TABLE 5-2
 LABORATORY SCALE KPEG TREATMENT
 OF OIL CONTAMINATED
 WITH HIGHLY CHLORINATED ORGANICS

Contaminants	Concentration in Untreated Oil (ppb)	Concentration in Treated Residue (ppb)	
		70°C, 15 min.	100°C, 30 min.
TCDD	28.2	N.D.	N.D.
TCDD	422	N.D.	N.D.
PeCDD	822	N.D.	N.D.
HxCDD	2982	N.D.	N.D.
TCDF	23.1	12.1	N.D.
TCDF	147	33.3	N.D.
PeCDF	504	N.D.	N.D.
HxCDF	3918	4.91	N.D.
HpCDF	5404	5.84	N.D.
OCDF	6230	N.D.	N.D.

000768

TCDD = Tetrachlorodibenzo-p-dioxins
 PeCDD = Pentachlorodibenzo-p-dioxins
 HxCDD = Hexachlorodibenzo-p-dioxins
 TCDF = Tetrachlorodibenzo-p-dioxins
 PeCDF = Pentachlorodibenzofurans
 HxCDF = Hexachlorodibenzofurans
 HpCDF = Heptachlorodibenzofurans
 OCDF = Octachlorodibenzofurans

Source: Rogers, et al., 1987

Because the field and lab tests have proven well, the reliability of this alternative is rated high, pending the results of a successful pilot scale treatability test at the ITS site.

Implementability - The implementability of this alternative may be measured by its constructability and by the time required for implementation. The technologies encompassed by this alternative are readily constructed on-site. Before excavation can begin, a pilot scale test must be implemented. The time required for implementation will be at least six months for a treatability study and another six months for full scale implementation.

The implementability of the alternative is rated moderate.

Safety - Evaluating this alternative with regard to safety requires examination of short and long term effects. Short term safety can be enhanced by the use of PPE and proper construction procedures. Long term safety is ensured only if all the PCBs are dechlorinated; however, toxicological tests performed on treated soils from previous tests show no adverse effects from the process byproducts (Rogers, et al., 1987).

The safety rating of the chemical treatment alternative is high. The overall technical evaluation rates moderate, again pending a successful treatability study at the ITS site before final implementation of this alternative.

5.1.9 Alternative 15 - In Situ Glassification

The in situ glassification process encompasses destroying organic contaminants in place through heating the soil with electricity through specially placed electrodes. The extremely high temperatures (3600°F) result in the combustion of the organic soil constituents, including PCBs. Products of the combustion are collected in an off-gas hood and treated. The remaining inorganic materials are solidified into a mass resembling natural obsidian.

000769

Performance - This alternative has been shown to effectively destroy and remove PCBs. An engineering scale test performed on soils contaminated with greater than 500 ppm PCBs showed a system DRE of greater than 99.9999%. Analysis of the vitrified block showed no residual PCBs, furans, or dioxins. In addition, a laboratory study showed the glassification process to be effective on different soil types (Fitzpatrick, et al., 1986; Fuerst, 1987). Because the end product exhibits properties of natural obsidian, the useful life of this alternative will be on the order of one million years.

The performance rating of the in situ glassification alternative is high.

Reliability - Reliability depends on the operation/maintenance requirements and prior demonstrated performance of the in situ glassification alternative. Once the glassification procedure has been completed, only minimal operation or maintenance activities will be required on-site. Prior demonstrated performance of in situ glassification consists of one engineering scale test that reduced PCBs from 500 ppm by greater than 99.9999% with no residual PCBs in the vitrified block. Engineering scale tests on soils contaminated with other constituents exhibit similar destruction/removal efficiencies.

While no successful field scale implementations of the in situ glassification has occurred for remediating PCBs, the method has shown great promise from the engineering test; therefore, the reliability rating for the in situ glassification alternative is high, pending the results of a pilot test at the ITS site.

Implementability - Both the constructability and the time required to implement the alternative are factors of the implementability. Constructability is easily attainable - a few holes will be drilled for installation of the electrodes and a crane will require overhead maneuvering room, which is readily

available, to move the off-gas hood. The time required for implementation is also reasonable (approximately 64 days) and competitive with other remediation technologies. However, this alternative may contribute to foundation problems of the buildings on-site as the treated soils subside.

The implementability of the in situ glassification alternative is rated low.

Safety - For both the short and long term, this alternative protects the safety of nearby populations. Since excavation is not required, workers implementing the remediation techniques are not exposed to PCB-contaminated dust that might normally be generated during those types of construction activities. PPE will further enhance the short term safety of the workers. Gases released during the treatment process are collected in a specially designed hood and then treated prior to release to the atmosphere. For the long term, this method yields a DRE of greater than 99.9999% and no PCBs can be detected remaining in the vitrified mass, which may be reclassified as a Class III waste, meaning it is inert and essentially insoluble.

The in situ glassification alternative receives a high safety rating, and the overall technical feasibility rates high, pending results of a successful field scale test at the ITS site.

5.2 INSTITUTIONAL ANALYSIS

This section presents an institutional analysis for each alternative based upon one category: conformance of the alternative with ARARs.

EPA policy is to comply with applicable or relevant environmental and public health standards when implementing CERCLA (Comprehensive Environmental Response, Compensation and Liability Act of 1980) remedial actions to the

ALTERNATIVE 15 - IN SITU CLASSIFICATION (Continued)

<u>Indirect Activity Costs</u>	<u>Cost Basis</u>	<u>Unit Cost</u>	<u>Total Cost</u>
1. Contingency	% of direct cost	10%	\$ 81,585
2. Engineering/ Design	% of direct cost	10%	\$ 81,585
3. Administration/Inspection	% of direct cost	4%	\$ 32,634
4. Permitting	% of direct costs	0.5%	\$ 4,079
5. Shakedown	% of direct costs	1.5%	\$ <u>12,238</u>
		Total Indirect Costs	\$ <u>212,121</u>
Total Capital Costs			\$1,027,970
<u>Annual Operation and Maintenance</u>			
1. Monitoring			\$ 10,000
2. Maintenance			\$ <u>0</u>
		Total Operation and Maintenance (Annual)	\$ <u>10,000</u>
GRAND TOTAL - Present Worth with 4% Interest Rate,			\$1,200,890

000772

extent possible, and primary consideration will be given to the alternative meeting or exceeding these standards. However, additional regulations, advisories, and guidance may also be considered in developing these remedies. Furthermore, SARA recommends that remedial actions taken shall permanently and significantly reduce the mobility, toxicity, or volume of hazardous material at a Superfund site (Section 121 (b) (1)) to the extent practicable.

The following list details additional regulations pertinent to the implementation of remedial actions at the ITS site.

1. Toxic Substances Control Act (TSCA) PCBs Manufacturing, Processing, Distribution in Commerce, and Use Prohibitors (40 CFR 761) - establishes prohibitions and requirements for the use, disposal, and storage of PCBs and PCB items.
2. Resource Conservation and Recovery Act (RCRA) (42 USC 6901) - enacted to regulate the management of hazardous waste and its generation, transport, treatment, storage, and disposal.
3. Clean Water Act (CWA) (33 USC 1251) - enacted to restore the chemical, physical, and biological integrity of the nation's waters.
 - a) National Pollution Discharge Elimination System (NPDES) (40 CFR 122) - governs point source releases to surface water bodies.
 - b) Toxic Pollutant Effluent Standards (TPES) (40 CFR 129) - prohibits the discharge of PCBs from any manufacturer who produces or assembles electrical transformers, where discharge includes stormwater run-off; however, Superfund sites are exempt from this standard.
4. Clean Air Act (CAA) (42 USC 7401) - enacted to protect and enhance the quality of the nation's air.
5. Safe Drinking Water Act (SDWA) (40 CFR 141) - enacted to protect public health by limiting contaminant concentrations present in public drinking water supplies.
 - a) Underground Injection Control (UIC) (40 CFR 146) - governs the use of injection wells for liquid disposal.
6. Occupational Safety and Health Act (OSHA) - emphasizes the need for standards to protect the health and safety of workers exposed to potential hazards at their workplace.

000773

7. National Institute for Occupational Safety and Health, 1977 (NIOSH) - set a limit of 1.0 ug/m³ PCBs in air for 10 hour worker exposure.
8. Department of Transportation (DOT) Shipping Regulations - specify that hazardous materials must be classified, packaged, marked, labelled, and shipped according to specifications listed in 49 CFR 172.

Each of the alternatives is evaluated with respect to attaining the requirements of pertinent federal, state, and local regulations. A low rating designates no compliance with pertinent laws, a moderate rating indicates compliance with many of the applicable laws, and a high rating indicates complete compliance with the applicable laws. Of note is the fact that all remedial actions necessitate leaving residual amounts of PCBs in the soils (less than the 25 ppm PCBs cleanup level) that may contribute to future migration of PCBs from the site. The overall institutional requirements rating then reiterates the results of conformance with ARARs evaluation.

The institutional evaluation ratings are listed in Table 5-3.

5.2.1 Alternative 1 - No Action

No attempt is made to comply with regulatory regulations with the no action alternative. In fact, with this type of remedial action, the site results in continuous exposure to the site hazards as described in the RI and could generate off-site contamination in excess of regulatory limits through the actions of wind and rain.

Conformance with ARARs - The no action alternative does not conform with certain ARARs. This alternative does not meet specifications of CERCLA, as amended by SARA (Section 121 (b)(1)), by not permanently and significantly reducing the mobility, toxicity, or volume of hazardous substances, pollutants,

TABLE 5-3

SUMMARY OF INSTITUTIONAL REQUIREMENTS EVALUATION

Alternative	Conformance with ARAR's	Overall Institutional Requirements
1. No Action	Low	Low
4. Excavation and Off-Site Landfill	Low	Low
6. Excavation, Stabilization, and Off-Site Landfill	Low	Low
7. Excavation and Off-Site Incineration	High	High
8. Excavation and On-Site Incineration	High	High
10. Excavation and Activated Sludge Treatment	High	High
11. Excavation and Contained Landfarm	High	High
12. Excavation and Chemical Treatment	High	High
15. In Situ Glassification	High	High

000775

and contaminants. In addition, the alternative does not control migration of contaminants, especially through run-off action. In fact, one surface water sample detected 0.17 ppm PCBs. It also violates TSCA by not meeting the 25 ppm PCBs criterion for soils in restricted areas.

The conformance of the no action alternative to ARARs is low and, therefore, the overall institutional requirement is rated low.

5.2.2 Alternative 4 - Excavation and Off-Site Landfill

Conformance with ARARs - The off-site landfill alternative demonstrates positive conformance with the various ARARs and does comply with Section 121 (b)(1) of CERCLA. This alternative does not permanently reduce the volume or toxicity of the contaminants; however, landfilling does immobilize the contaminants by reducing infiltration for as long as the cap and liner remain intact. This alternative will meet the particulate standards during excavation by providing for fugitive dust control. It also meets the TSCA rule for cleanup of PCB-contaminated soils. Excavation activities will meet OSHA rules by ensuring that all workers have participated in extensive safety training. While construction activities may result in exceeding the NIOSH air quality limit regarding PCBs, workers will be wearing at least half-face respirators while on-site to decrease their inhalation exposure to PCBs. DOT shipping regulations must be met by the trucking firm transporting the contaminated materials. Finally, the landfill must meet PCB landfill requirements as specified in 40 CFR 761.75. Even so, landfilling regulations are approaching a landban for various materials under SARA, and the agencies are looking for alternatives other than landfilling. Therefore, this is an undesirable alternative.

The off-site landfill alternative rates low for the conformance to ARARs analysis, and the overall institutional analysis results in a low rating.

5.2.3 Alternative 6 - Excavation, Stabilization, and Off-Site Landfill

Conformance with ARARs - This alternative demonstrates conformance with the various ARARs. This alternative complies with Section 121 (b)(1) of CERCLA by immobilizing the wastes in the landfill. This alternative will meet the particulate standards during excavation by providing for fugitive dust control and the TSCA rule for cleanup of PCB-contaminated soils. Excavation activities will meet OSHA rules by ensuring that all workers have participated in the required safety training. While construction activities may result in the exceedance of the NIOSH air quality limit regarding PCBs, workers will be wearing at least half-face respirators while on-site to decrease their inhalation exposure to PCBs. DOT shipping specifications must be met by the trucking firm transporting the PCB-contaminated soils. Finally, the off-site landfill must meet PCB landfill requirements as specified in 40 CFR 761.75. Even so, landfilling regulations are approaching a landban for various materials and the agencies try to avoid landfilling. Therefore, this is an undesirable alternative.

Therefore, this alternative rates low for conformance to ARARs and for the overall institutional analysis.

5.2.4 Alternative 7 - Excavation and Off-Site Incineration

Conformance with ARARs - This alternative demonstrates compliance with the ARARs. The alternative complies with Section 121 (b)(1) of CERCLA by destroying the contaminants. Excavation activities associated with implementing this alternative will meet the particulate standards by utilizing fugitive dust control measures and the OSHA rules by ensuring that all workers have participated in the required safety training program. The alternative meets the TSCA cleanup level of 25 ppm PCBs. Excavation may result in the violation of NIOSH air quality standards, but half or full-face respirators will ensure that the workers are not exposed to PCBs via the inhalation route. The trucking firm hired to transport the contaminated materials will meet DOT shipping

regulations. Finally, the incinerator will meet the PCB incineration requirements as specified in 40 CFR 761.70.

This alternative conforms to the applicable ARARs; therefore, the off-site incineration alternative receives a high rating for conformance with ARARs and for overall institutional requirements.

5.2.5 Alternative 8 - Excavation and On-Site Incineration

Conformance with ARARs - The on-site incineration alternative also conforms with most of the ARARs. In accordance with TSCA, soils in excess of 25 ppm PCBs are excavated and incinerated. In addition, this alternative meets SARA recommendations by destroying the contaminants. The ash can be reclassified to nonhazardous under RCRA. Fugitive dust control measures shall be performed to prevent violation of the CAA. PPE will protect site workers as determined by NIOSH, and all workers will be required to have previously completed an approved OSHA safety training course.

Incinerator requirements, as specified by 40 CFR 761.70, are:

- Air emissions shall be less than 0.001 g PCB/kg PCB introduced into the incinerator, or 0.0001%.
- Combustion efficiency shall be at least 99.9%.
- Temperatures, rate and quantity of feed rate shall be measured and recorded.
- Stack emissions will be monitored for at least O₂, CO, and CO₂.
- Soil flow to the incinerator will stop automatically when one of a myriad of conditions is met, including:
 - Failure of monitoring operations;
 - Failure of measuring and recording equipment, or
 - Excess oxygen content falling below 3%.
- The incinerator will use water scrubbers to control hydrochloric acid (HCl) formation.

- The operator of the incinerator must receive written approval from the EPA Regional Administrator. Part of the approval includes a possible test burn.

Therefore, the on-site incineration alternative rates high for conformance to ARARs.

Based on the above evaluations, the overall institutional evaluation rates high.

5.2.6 Alternative 10 - Excavation and Activated Sludge Treatment

Conformance with ARARs - This alternative also conforms with the ARARs. In conformance with TSCA, the soils containing greater than 25 ppm PCBs are excavated and treated. This alternative fulfills Section 121 (b)(1) by destroying the PCBs. The treated soils can be tested and reclassified under RCRA rules. Fugitive dust control measures will be performed to prevent violation of the CAA. PPE will be used by the site workers to preclude violation of NIOSH regulations. All workers will have completed an approved OSHA safety training course prior to commencing site work.

Therefore, this alternative receives a high rating for conformance to ARARs and for the overall institutional analysis.

5.2.7 Alternative 11 - Excavation and Contained Landfarm

Conformance with ARARs - This alternative also conforms with the ARARs. In accordance with TSCA, the soils containing greater than 25 ppm PCBs are excavated and treated. This alternative fulfills Section 121 (b)(1) by destroying the contaminants. Fugitive dust control measures shall be performed to prevent violation of the CAA. Workers are required to have taken an approved OSHA safety training course, and they will wear appropriate PPE to

prevent violation of NIOSH standards. Finally, the treated soils may be reclassified under RCRA rules and backfilled on-site.

This alternative receives a high rating for conformance with ARARs. Therefore, the contained landfarm alternative rates high for the overall institutional requirements analysis.

5.2.8 Alternative 12 - Excavation and Chemical Treatment

Conformance with ARARs - The chemical treatment alternative, like most of the other remedial alternatives, conforms to most of the ARARs. In compliance with TSCA, this alternative will be considered effective only if it destroys the PCBs to less than 25 ppm, and therefore, this alternative significantly reduces the toxicity of the contaminants, as preferred by SARA. Fugitive dust will be controlled to remain in compliance with the CAA. All workers shall have participated in a safety training program in accordance with OSHA, and the health of the workers shall be protected for the short term with PPE as required by NIOSH. Finally, the treated soils may be reclassified under RCRA requirements.

The conformance to ARARs for the chemical treatment alternative rates high, and the overall institutional analysis also rates high.

5.2.9 Alternative 15 - In Situ Glassification

Conformance with ARARs - The in situ glassification alternative conforms to most of the ARARs by destroying the organic contaminants, immobilizing inorganics, and removing soil void spaces to reduce soil volume. Because it reduces the volume, mobility, and toxicity of the contaminants, this alternative conforms with Section 121 (b)(1) of SARA. Since little or no construction is required by this alternative, neither the CAA nor the NIOSH air quality standards will be violated. Furthermore, all site workers will be properly trained as specified by OSHA.

Therefore, the conformance to ARARs for the in situ glassification alternative rates high.

Based on the above evaluation, this alternative shows an overall high rating for meeting the institutional requirements.

5.3 PUBLIC HEALTH ANALYSIS

This section provides information on the degree to which each remedial alternative protects public health, welfare, and the environment both during and after implementation of the alternative. The public health evaluations consider:

- The minimization or prevention of contaminant releases both during and after remedial activities,
- Nearby population exposure levels during remedial activities, and
- Population exposures after remedial activities.

Other criteria suggested by EPA guidance documents, such as EPA (1985), were not expressly addressed in this section because they are addressed elsewhere.

Similar to the evaluations using previous criteria, this evaluation was made quantitative by utilizing the terms "low", "moderate", and "high" to denote minimal, moderate, and high protection (respectively) of nearby populations from threats posed by each particular alternative. Finally, a summary public health analysis rating is obtained by assigning numerical values to the individual ratings and averaging them. The public health evaluations are depicted in Table 5-4.

TABLE 5-4
SUMMARY OF PUBLIC HEALTH EVALUATIONS

Alternative	Minimization or or Prevention Contaminant Release	Exposure Levels During Remediation	Exposure Levels After Remediation	Overall Public Health Evaluation
1. No Action	Low	Low	Low	Low
4. Excavation and Off-Site Landfill	Moderate	Moderate	High	Moderate
6. Excavation, Stabilization, and Off-Site Landfill	Moderate	Moderate	High	Moderate
7. Excavation and Off-Site Incineration	High	Moderate	High	High
8. Excavation and On-Site Incineration	High	Moderate	High	High
10. Excavation and Activated Sludge Treatment	High	Moderate	High	High
11. Excavation and Contained Landfarm	High	Moderate	High	High
12. Excavation and Chemical Treatment	High	Moderate	High	High
15. In Situ Glassification	High	High	High	High

000782

5.3.1 Alternative 1 - No Action

Minimization or Prevention of Contaminant Release - The no action alternative does not prevent or minimize contaminant releases. Therefore, the no action alternative receives a low rating for this criterion.

Exposure Levels During Remediation - Since the no action alternative requires no remedial work to be done on-site, exposure levels to nearby populations should remain low. However, this alternative receives a low rating for this criterion because it provides no control action on the contaminated areas.

Exposure Levels After Remediation - Because site conditions remain unchanged by this alternative, exposure levels are also unchanged. Therefore, the no action alternative receives a low rating for this criterion.

The overall public health evaluation is low for the no action alternative.

5.3.2 Alternative 4 - Excavation and Off-Site Landfill

Minimization or Prevention of Contaminant Release - The off-site landfill also results in a drastic minimization of contaminant release. Because the soils contaminated in excess of 25 ppm are removed and landfilled off-site, this alternative minimizes further contaminant release. However, the possibility of the landfill leaking at some future date does exist; therefore, the off-site landfill alternative receives a moderate rating for minimizing or preventing contaminant release.

Exposure Levels During Remediation - During remediation activities, contaminated dust and direct contact with contaminated soils become more of a problem. However, dust control measures and PPE remove most of the increased exposure levels. Therefore, the off-site landfill alternative receives a moderate rating for this criterion.

Exposure Levels After Remediation - The off-site landfill alternative provides for greatly reduced exposure levels after remediation. Thus, this criterion receives a high rating.

The overall public health criterion for the off-site landfill alternative receives a moderate rating.

5.3.3 Alternative 6 - Excavation, Stabilization, and Off-Site Landfill

Minimization or Prevention of Contaminant Release - This alternative also results in a drastic minimization of contaminant release. Because the soils contaminated in excess of 25 ppm PCBs are removed, stabilized, and landfilled off-site, this alternative minimizes further contaminant release. However, the possibility of a landfill leak at some future date does exist. If infiltration and leachate generation are substantial enough, the stabilization step will not provide much additional protection in reducing contaminant release. Therefore, this alternative receives a moderate rating for this criterion.

Exposure Levels During Remediation - During remediation activities, contaminated dust and direct contact with contaminated soils become more of a problem. However, dust control measures and PPE remove most of the increased exposure levels. Therefore, the off-site landfill alternative receives a moderate rating for this criterion.

Exposure Levels After Remediation - The off-site landfill alternative provides for greatly reduced exposure levels to meet TSCA requirements once remediation is complete. Thus, this criterion receives a high rating.

The overall public health criterion for the stabilization and off-site landfill alternatives receives a moderate rating.

5.3.4 Alternative 7 - Excavation and Off-Site Incineration

Minimization or Prevention of Contaminant Release - The off-site incineration alternative greatly reduces contaminant release by destroying PCBs in the excavated soils. Therefore, this alternative receives a high rating for minimizing and preventing contaminant release.

Exposure Levels During Remediation - The remediation activities required to implement the off-site incineration alternative have the potential for worker and residential population exposure by stirring up dust and hauling contaminated soils. However, both dust control measures and PPE will minimize potential exposure levels during remediation, and operation of the incinerator in accordance with TSCA regulations will further protect public health by meeting the stringent TSCA standards of greater than 99.9999% DRE. In addition, potential exposure also exists during transportation to the incineration facility. Therefore, this alternative exhibits a moderate rating for controlling exposure levels during remediation.

Exposure Levels After Remediation - The off-site incineration alternative results in greatly lowered exposure levels once remediation has been completed. Therefore, this alternative receives a high rating for mitigating exposure levels after remediation.

The on-site incineration alternative receives a high overall public health evaluation rating.

5.3.5 Alternative 8 - Excavation and On-Site Incineration

Minimization or Prevention of Contaminant Release - The on-site incineration alternative greatly reduces contaminant release by destroying PCBs in the excavated soils. Therefore, this alternative receives a high rating for minimizing and preventing contaminant release.

Exposure Levels During Remediation - The remediation activities required to implement the on-site incineration alternative have the potential for worker and residential population exposure by stirring up dust and hauling contaminated soils. However, both dust control measures and PPE will minimize potential exposure levels during remediation, and operation of the incinerator in accordance with TSCA regulations will further protect public health by meeting the stringent TSCA standards of greater than 99.9999% DRE. Therefore, this alternative exhibits a moderate rating for controlling exposure levels during remediation.

Exposure Levels After Remediation - The on-site incineration alternative results in greatly lowered exposure levels once remediation has been completed. Therefore, this alternative receives a high rating for mitigating exposure levels after remediation.

The on-site incineration alternative receives a high overall public health evaluation rating.

5.3.6 Alternative 10 - Excavation and Activated Sludge Treatment

Minimization or Prevention of Contaminant Release - The activated sludge alternative results in the prevention of contaminant release by degrading the PCBs. Consequently, this alternative receives a high rating for this criterion. A pilot scale treatability study is recommended before fully implementing this alternative at the ITS site.

Exposure Levels During Remediation - During excavation, contaminated dust and direct contact with contaminated soils become more of a problem. Dust control measures and PPE combat the increased exposure levels. Using an enclosed reactor will decrease contact of the workers with the PCBs. This alternative receives a moderate rating for this criterion.

Exposure Levels After Remediation - The activated sludge alternative results in greatly reduced concentrations of PCBs once remediation is complete. Therefore, this alternative receives a high rating regarding exposure levels after remediation.

The overall public health rating for the activated sludge process is high pending pilot scale testing.

5.3.7 Alternative 11 - Excavation and Contained Landfarm

Minimization or Prevention of Contaminant Release - The contained landfarm alternative prevents contaminant release by destroying the PCBs. However, a pilot scale test is recommended prior to full scale implementation to prove the effectiveness of the method. This alternative receives a high rating for this criterion pending pilot scale testing.

Exposure Levels During Remediation - The excavation and tilling activities associated with this alternative create a potential for worker and residential population exposure by stirring up dust. Dust control measures and PPE minimize the exposure levels during remediation. Therefore, this alternative exhibits a moderate rating for controlling exposure levels during remediation.

Exposure Levels After Remediation - The contained landfarm alternative results in greatly reduced exposure levels by degrading the PCBs. Therefore, this alternative receives a high rating for mitigating exposure levels after remediation.

The overall public health rating for the contained landfarm alternative is high.

5.3.8 Alternative 12 - Excavation and Chemical Treatment

Minimization or Prevention of Contaminant Release - The chemical treatment alternative greatly minimizes contaminant release by destroying the PCBs. Therefore, this alternative receives a high rating for this public health evaluation category.

Exposure Levels During Remediation - Because excavation is required to implement this alternative, exposure levels during remediation will be similar to those from excavation activities for other alternatives. Dust control measures will be utilized. PPE will protect workers during remediation, and therefore, off-site exposure levels should be quite small. Consequently, the chemical treatment alternative receives a moderate rating for controlling exposure levels during remediation.

Exposure Levels After Remediation - The chemical treatment alternative results in greatly decreased exposure levels of PCBs. Therefore, this alternative rates high for the exposure levels after remediation category. However, before implementation of this alternative, a pilot scale test would be required at the ITS site to prove this remedial method effective.

The overall public health evaluation rating for the chemical treatment alternative is high pending pilot scale testing.

5.3.9 Alternative 15 - In Situ Glassification

Minimization or Prevention of Contaminant Release - The in situ glassification alternative greatly reduces contaminant release by destroying the contaminants in the treated soils. Consequently, the in situ glassification alternative receives a high rating on minimizing and preventing contaminant release. However, a pilot test is recommended before fully implementing this alternative at the ITS site.

Exposure Levels During Remediation - The exposure levels of nearby residential and worker populations for this alternative are substantially lower than for those alternatives requiring excavation of contaminated soils. The off-gas hood collects any airborne contaminants. Thus, this alternative rates high regarding exposure levels during remediation.

Exposure Levels After Remediation - Treating the soils containing greater than 25 ppm PCBs results in a greatly reduced potential exposure level after remediation. Therefore, the in situ glassification alternative rates high regarding exposure levels after remediation.

The overall public health rating is high for the in situ glassification alternative.

5.4 ENVIRONMENTAL IMPACTS ANALYSIS

Each remedial alternative will be evaluated for its beneficial and adverse environmental impacts. The beneficial effects evaluation details the final environmental conditions, the improvements in the biological environment, and the improvements in human use of the on-site resources for each alternative. The adverse effects evaluation explores the adverse effects of both the construction/operation activities and the mitigative measures.

As for the other analyses, the environmental impacts analysis encompasses a quantitative evaluation of the alternatives through a scaled rating using "high", "moderate", and "low". A high rating indicates a high beneficial promotion of environmental concerns such as the removal or destruction of contaminants, reduction of contaminant migration, and restoration of original site use. A low rating indicates that the alternative either contributes to or does not mitigate adverse effects at the site. Adverse effects at the ITS site include temporary removal of site vegetation, potential for contaminant migration during construction, and noise and dust caused by construction equipment.

Finally, each alternative is allotted an overall environmental impacts rating that is obtained by assigning a numerical value to the ratings of "high", "moderate", or "low" and averaging the values to obtain a final, overall rating. A summary of the environmental impacts analysis is presented in Table 5-5.

5.4.1 Alternative 1 - No Action

Beneficial Effects - The no action alternative offers no beneficial effects. Local populations will continue to be exposed to on-site contaminants. Therefore, the no action alternative receives a low rating for beneficial effects.

Adverse Effects - The no action alternative includes no construction or operation measures and provides no mitigative effects. Exposure to and migration of site contamination will continue. Therefore, this alternative acquires a low rating for mitigation of the adverse environmental impacts.

The no action alternative receives an overall environmental impacts rating of low.

5.4.2 Alternative 4 - Excavation and Off-Site Landfill

Beneficial Effects - The off-site landfill alternative results in the removal, deportation, and subsequent off-site landfilling of all soils contaminated with PCBs in excess of 25 ppm. This means greatly improved final environmental conditions on-site. In addition, biological populations are better protected from PCBs and human use of resources becomes safer. Site improvements occur through removal of highly contaminated soils from the site. Therefore, the off-site landfill alternative provides a high rating for beneficial effects.

000790

TABLE 5-5
SUMMARY OF ENVIRONMENTAL IMPACTS ANALYSIS

Alternative	Beneficial Effects Rating	Adverse Effects Rating	Overall Environmental Impacts Rating
1. No Action	Low	Low	Low
4. Excavation and Off-Site Landfill	High	Moderate	Moderate
6. Excavation, Stabilization, and Off-Site Landfill	High	Moderate	Moderate
7. Excavation and Off-Site Incineration	High	Moderate	Moderate
8. Excavation and On-Site Incineration	High	Moderate	Moderate
10. Excavation and Activated Sludge Treatment	High	Moderate	Moderate
11. Excavation and Contained Landfarm	High	Moderate	Moderate
12. Excavation and Chemical Treatment	High	Moderate	Moderate
15. In Situ Glassification	High	Moderate	Moderate

000791

Adverse Effects - Implementation of this alternative also results in potential adverse effects during the construction phase. These adverse effects include:

- Temporary removal of site vegetation causing potential contaminant migration; and
- Additional dust, noise, and traffic caused by construction equipment.

All of these adverse effects are temporary, and the severity may be mitigated by implementing dust and noise control actions. Therefore, this alternative receives a moderate rating for controlling adverse effects.

The overall environmental impacts rating for the off-site landfill alternative is moderate.

5.4.3 Alternative 6 - Excavation, Stabilization, and Off-Site Landfill

Beneficial Effects - This off-site landfill alternative also results in the removal, stabilization, deportation, and subsequent off-site landfilling of all soils contaminated with PCBs in excess of 25 ppm. This means greatly improved conditions on-site, and the stabilization should further protect the conditions off-site at the landfill. Therefore, the populations are better protected from the health threat caused by the PCBs and the human use resources become safer to use. Site improvements occur through the removal of highly contaminated soils from the site. Therefore, the stabilization and off-site landfill alternative provides a high rating for beneficial effects.

Adverse Effects - Implementation of this alternative also results in adverse effects during the removal phase. These adverse effects include:

- Temporary removal of site vegetation, creating the added potential for contaminant migration; and
- Additional dust, noise, and traffic caused by construction equipment.

All of these adverse effects are temporary, and the severity may be mitigated by implementing dust and noise control actions. Therefore, this alternative receives a moderate rating for controlling adverse effects.

The overall environmental impacts rating for the stabilization and off-site landfill alternative is moderate.

5.4.4 Alternative 7 - Excavation and Off-Site Incineration

Beneficial Effects - The off-site incineration alternative also results in a variety of beneficial effects. Incineration destroys virtually all of the contaminants in the excavated soils. The contaminant destruction reduces the migration potential once the alternative has been implemented. In addition, this alternative will interfere little with commercial site activities. Thus, off-site incineration receives a high rating for promoting beneficial environmental effects.

Adverse Effects - Off-site incineration results in various temporary adverse effects such as removal of vegetation creating an increased potential for contaminant migration and elevated levels of noise, dust, and traffic due to the construction activities. However, these adverse effects are only temporary and can be partially mitigated through the use of dust, noise, and surface water control measures. Transportation to the incineration facility may lead to accidental spillage of the PCB contaminated soils; however, choosing a reliable trucking firm minimizes this threat. Therefore, this alternative has a moderate rating for reducing adverse environmental effects.

From the above discussion, the overall environmental impacts rating for on-site incineration is moderate.

5.4.5 Alternative 8 - Excavation and On-Site Incineration

Beneficial Effects - The on-site incineration alternative also results in a variety of beneficial effects. Incineration destroys virtually all of the contaminants in the excavated soils. The contaminant destruction reduces the migration potential once the alternative has been implemented. In addition, this alternative will interfere little with commercial site activities. Thus, on-site incineration receives a high rating for promoting beneficial environmental effects.

Adverse Effects - On-site incineration results in various temporary adverse effects such as removal of vegetation creating an increased potential for contaminant migration and elevated levels of noise, dust, and traffic due to the construction activities. However, these adverse effects are only temporary and can be partially mitigated through the use of dust, noise, and surface water control measures. Therefore, this alternative has a moderate rating for reducing adverse environmental effects.

From the above discussion, the overall environmental impacts rating for on-site incineration is moderate.

5.4.6 Alternative 10 - Excavation and Activated Sludge Treatment

Beneficial Effects - The activated sludge alternative results in a variety of beneficial effects. The activated sludge process has the potential to degrade the PCBs to innocuous byproducts, which in turn reduces the migration potential. This alternative will interfere little with the commercial site activities. Thus, this alternative receives a high rating for promoting beneficial environmental effects.

Adverse Effects - The activated sludge method results in various temporary adverse effects such as the removal of vegetation, which increases the potential for contaminant migration, and elevated levels of noise, dust,

and traffic due to the excavation activities. However, these adverse effects are only temporary and can be partially mitigated through the use of dust, noise, and surface water control measures. Therefore, this alternative has a moderate rating for reducing adverse environmental effects.

The overall environmental impacts rating for the activated sludge alternative is moderate.

5.4.7 Alternative 11 - Excavation and Contained Landfarm

Beneficial Effects - The contained landfarm alternative results in a variety of beneficial effects. The landfarm process has the potential to degrade the PCBs to innocuous byproducts, which in turn reduces the migration potential. This alternative will interfere little with the commercial site activities. Thus, this alternative receives a high rating for promoting beneficial environmental effects.

Adverse Effects - The landfarm method results in various temporary adverse effects such as the removal of vegetation, which increases the potential for contaminant migration, and elevated levels of noise, dust, and traffic due to the excavation activities. However, these adverse effects are only temporary and can be partially mitigated through the use of dust, noise, and surface water control measures. Therefore, this alternative has a moderate rating for reducing adverse environmental effects.

The overall environmental impacts rating for the landfarm alternative is moderate.

5.4.8 Alternative 12 - Excavation and Chemical Treatment

Beneficial Effects - Chemical treatment provides many beneficial effects. This alternative has the potential to destroy the PCBs in the treatment area to the desired level. Destruction of the PCBs results in increased safety to biological populations and in continued commercial use of the site.

000795

For these reasons, this alternative results in a high rating for beneficial environmental effects.

Adverse Effects - Implementing the chemical treatment alternative results in few adverse environmental effects. In this case, the adverse effects are construction-related and temporary. The temporary adverse effects include vegetation removal and the resulting increased potential for contaminant migration in addition to increased levels of noise and dust caused by the heavy equipment. These temporary adverse effects can be controlled by utilizing noise, dust, and surface water control measures. Consequently, a moderate rating is given to this alternative for controlling adverse effects.

Thus, the overall environmental impacts rating for the chemical treatment alternative is moderate.

5.4.9 Alternative 15 - In Situ Glassification

Beneficial Effects - The in situ glassification alternative results in a variety of beneficial effects. Foremost, this alternative destroys virtually all of the contaminants in the treatment area, which in turn reduces contaminant migration and does not interfere with current site use. Consequently, in situ glassification receives a high rating for promoting beneficial environmental effects.

Adverse Effects - The in situ glassification alternative results in fewer adverse effects than other alternatives because this alternative destroys the contaminants and requires little construction. Adverse effects encountered during implementation of the alternative include:

- Temporary vegetation removal,
- Potential contaminant migration,
- Increased noise and traffic caused by the heavy equipment, and
- Potential foundation problems caused by the subsidence associated with this alternative.

However, all except one of these adverse effects are temporary, and the alternative provides for destruction of the contaminants. For this reason, this alternative receives a moderate rating for controlling adverse effects.

The overall environmental impacts rating for in situ glassification is moderate.

5.5 COST ANALYSIS

Cost analyses incorporate three tasks as specified in the EPA Guidance on Feasibility Studies under CERCLA (1985). These are:

- Estimation of Costs,
- Present Worth Analysis, and
- A Sensitivity of Cost to Changes in Key Parameters.

Cost estimates reflect site-specific conditions and include capital costs and operation/maintenance costs for all alternatives. The cost estimates represent a -30% to +50% accuracy. Present worth analyses are useful to compare the costs of different alternatives by computing the current value of all costs incurred including those incurred in the present or at some future date. Finally, the cost screening analysis consists of comparing the present worth costs of alternatives with similar environmental, public health, and public welfare benefits to the other alternatives. The cost screening can be used to eliminate those alternatives that offer similar or fewer environmental and public health benefits, with no greater reliability, and at a cost of an order of magnitude greater. However, more expensive alternatives offering substantially greater environmental or health benefits should not be eliminated.

Cost estimates are based upon the conceptual designs as discussed in Section 3. The estimates for the capital and operation/maintenance costs are expressed in 1987 dollars.

Total capital costs were developed under two categories: direct and indirect costs. Costs for each remedial alternative were derived from literature sources, vendor quotes, and previous studies. Table 5-6 shows a summary of the capital cost breakdowns for each alternative. A more detailed cost breakdown may be found in Appendix B. Direct cost assumptions are listed below:

- The amount of soil to be remediated was increased from that listed in the RI to account for possible extension of the remediation boundaries because of localized hot spots and then multiplied by a 15 percent bulking factor.
- Stabilization was assumed to increase soil volumes by 50 percent.

Indirect capital costs include such factors as engineering, design, administration, inspection, contingency, preparation of permits, and shakedown, where shakedown costs include those costs required for field testing or for bringing the alternative into complete functional operation once construction has been completed. Indirect capital costs calculations require the following assumptions:

- Contingency allowances were based on 10 percent of the total direct construction cost.
- Engineering and design allowances were also based on 10 percent of the total direct construction cost.
- Administration and inspection expenses were calculated as 4 percent of the total direct construction cost.
- Permitting costs ranged from 0 to 5 percent of the total direct construction costs, depending on the complexity of the tasks required to meet permit specifications (obtaining the actual permit is not required at Superfund sites).
- Shakedown costs varied from 0 to 1.5 percent of the total direct cost and were added if the treatment process required preliminary adjustments in operation.

Annual operation and maintenance costs for each alternative were based upon estimated labor and materials costs in addition to sampling and analysis requirements. Itemized operation and maintenance costs are shown in Appendix B and summarized in Table 5-6.

TABLE 5-6
SUMMARY OF COST ESTIMATES FOR 4% INTEREST RATE

Remedial Alternative	Capital Cost	Annual Operation and Maintenance	Present Worth of O and M at 4% for 30 years	Total Cost
1.No Action	\$ 29,512	\$10,000	\$172,920	\$ 202,432
4.Excavation and Off-Site Landfill	1,844,365	10,000	172,920	2,017,285
6.Excavation, Stabilization, and Off-Site Landfill	3,000,935	10,000	172,920	3,173,855
7.Excavation and Off-Site Incineration	5,665,660	10,000	172,920	5,838,580
8.Excavation and On-Site Incineration	1,983,766	10,000	172,920	2,156,686
10.Excavation and Activated Sludge Treatment	2,889,637	10,000	172,920	3,062,557
11.Excavation and Contained Landfarm	2,148,126	10,000	172,920	2,321,046
12.Excavation and Chemical Treatment	1,789,414	10,000	172,920	1,962,334
15.In Situ Glassification	1,027,970	10,000	172,920	1,200,890

1000799

A present worth analysis is used to facilitate a cost comparison between alternatives requiring different amounts of operation and maintenance by discounting future costs to a common monetary basis, the present worth. Present worth can be calculated with the following formula:

$$PW = PWF (O + M) + TCC$$

where PW = present worth,
PWF = present worth factor based upon a 4 percent interest rate over a period of 30 years,
O + M = annual operation and maintenance costs, and
TCC = total capital cost.

Even though the PWF is based on an annual interest rate of 4 percent and a thirty year time period, no inflation factors have been included. The 4 percent interest rate was chosen to yield conservative cost estimates. Furthermore, while maintenance of the PCB wastes will be required in perpetuity, the EPA Guidance Document (EPA, 1985) prescribes a planned life of a facility for analysis to a maximum of 30 years. Present worth analyses are also shown in detail in Appendix B and are summarized in Table 5-6.

Once the present worth analyses have been completed, a sensitivity analysis was performed on the costs to evaluate the effects of small variations in cost assumptions on the final cost. Perhaps the parameter whose value is most unknown or least certain is the interest rate. Therefore, the sensitivity analysis details the effects of three different interest rates on the total, 30 year costs of each alternative. A summarized version of the sensitivity analysis is shown in Table 5-7. The sensitivity analysis shows that the present worth of each alternative increases as the interest rate decreases because with a higher interest rate less money is required initially to finance annual operation and maintenance activities over a 30 year period. Alternatives with high annual operation and maintenance costs relative to the total capital costs are more sensitive to changes in interest rates. However, the total costs are found to be insensitive to interest rates.

TABLE 5-7. SENSITIVITY ANALYSIS OF ALTERNATIVES

Costs	1. No Action	4. Excavation and Off-Site Landfill	6. Excavation, Stabilization, and Off-Site Landfill	7. Excavation and Off-Site Incineration	8. Excavation and On-Site Incineration	10. Excavation and Activated Sludge	11. Excavation and Contained Landfarm	12. Excavation and Chemical Treatment	15. In Situ Classification
Total Capital Costs	\$ 29,512	\$1,844,365	\$3,000,935	\$5,665,660	\$1,983,766	\$2,889,637	\$2,148,126	\$1,789,414	\$1,027,970
Annual O & M	\$ 10,000	\$ 10,000	\$ 10,000	\$ 10,000	\$ 10,000	\$ 10,000	\$ 10,000	\$ 10,000	\$ 10,000
4% Present Worth - Capital	\$ 29,512	\$1,844,365	\$3,000,935	\$5,665,660	\$1,983,766	\$2,889,637	\$2,148,126	\$1,789,414	\$1,027,970
O & M	172,920	172,920	172,920	172,920	172,920	172,920	172,920	172,920	172,920
Total Cost	\$202,432	\$2,017,285	\$3,173,855	\$5,838,580	\$2,156,686	\$3,062,557	\$2,321,046	\$1,962,334	\$1,200,890
Total Capital Costs	\$ 29,512	\$1,844,365	\$3,000,935	\$5,665,660	\$1,983,766	\$2,889,637	\$2,148,126	\$1,789,414	\$1,027,970
Annual O & M	\$ 10,000	\$ 10,000	\$ 10,000	\$ 10,000	\$ 10,000	\$ 10,000	\$ 10,000	\$ 10,000	\$ 10,000
7% Present Worth - Capital	\$ 29,512	\$1,844,365	\$3,000,935	\$5,665,660	\$1,983,766	\$2,889,637	\$2,148,126	\$1,789,414	\$1,027,970
O & M	124,090	124,090	124,090	124,090	124,090	124,090	124,090	124,090	124,090
Total Cost	\$153,602	\$1,968,455	\$3,125,025	\$5,789,750	\$2,107,856	\$3,013,727	\$2,272,216	\$1,913,504	\$1,152,060
Total Capital Costs	\$ 29,512	\$1,844,365	\$3,000,935	\$5,665,660	\$1,983,766	\$2,889,637	\$2,148,126	\$1,789,414	\$1,027,970
Annual O & M	\$ 10,000	\$ 10,000	\$ 10,000	\$ 10,000	\$ 10,000	\$ 10,000	\$ 10,000	\$ 10,000	\$ 10,000
10% Present Worth - Capital	\$ 29,512	\$1,844,365	\$3,000,935	\$5,665,660	\$1,983,766	\$2,889,637	\$2,148,126	\$1,789,414	\$1,027,970
O & M	94,269	94,269	94,269	94,269	94,269	94,269	94,269	94,269	94,269
Total Cost	\$123,781	\$1,938,634	\$3,095,204	\$5,759,929	\$2,078,035	\$2,983,906	\$2,242,395	\$1,883,683	\$1,122,239

5-47

000801

Considering failure costs was required. Failure costs are those costs incurred by implementing a new alternative when the original alternative has failed to achieve the remedial objectives. The innovative alternatives are more likely to fail than the more proven alternatives. Treatability studies have been recommended for the innovative alternatives, and the likelihood of failure may be determined during these tests. Because the treatability study in no way worsens the contamination situation, the failure cost will consist of the treatability study costs plus the cost of implementing one of the more traditional, proven methods of PCB remediation. All of these costs are presented in Appendix A.

A final cost analysis summary is provided in Table 5-8. Capital costs, operation and maintenance costs, and present worth costs for an interest rate of 4% are presented.

5.6 SUMMARY OF ALTERNATIVES

This section presents a summary of the detailed evaluation of the alternatives, shown in Table 5-8. Also presented are the major advantages and disadvantages of each alternative.

5.6.1 Alternative 1 - No Action

Advantages - The main advantage of Alternative 1 is the low cost. This alternative requires no remedial action. Only environmental monitoring will take place at the site.

Disadvantages - The disadvantages of this alternative include the continued health risks to population receptors contacting contaminants from the site, noncompliance with ARARs, and contaminant migration.

TABLE 5-8
SUMMARY OF DETAILED EVALUATIONS OF FINAL ALTERNATIVES

Remedial Alternative	Technical Feasibility Analysis	Institutional Requirements Analysis	Public Health Analysis	Environmental Impact Analysis	Total Present Worth
1. No Action	Low	Low	Low	Low	\$ 202,432
4. Excavation and Off-Site Landfill	High	Low	Moderate	Moderate	\$2,017,285
6. Excavation, Stabiliza- tion and Off-Site Landfill	High	Low	Moderate	Moderate	\$3,173,855
7. Excavation and Off-Site Incineration	High	High	High	Moderate	\$5,838,580
8. Excavation and On-Site Incineration	High	High	High	Moderate	\$2,156,686
10. Excavation and Activated Sludge Treatment	Moderate*	High	High	Moderate	\$3,062,557
11. Excavation and Contained Landfarm	Moderate*	High	High	Moderate	\$2,321,046
12. Excavation and Chemical Treatment	Moderate*	High	High	Moderate	\$1,962,334
15. In Situ Glassification	High*	High	High	Moderate	\$1,200,890

300800

* Rating may change based on recommended treatability studies.

5.6.2 Alternative 4 - Excavation and Off-Site Landfill

Advantages - The off-site landfill alternative results in the removal of all soils contaminated in excess of 25 ppm PCB from the site, which will protect local receptors.

Disadvantages - The major disadvantage of this alternative is the possibility of landfill failure. In addition, the potential for release of PCBs during transport to the landfill exists.

5.6.3 Alternative 6 - Excavation, Stabilization, and Off-Site Landfill

Advantages - This alternative offers similar advantages to those of the off-site landfill alternative, including the greatly reduced level of risk as compared to no action afforded to nearby receptors by stabilizing and placing the contaminated soils in a secure landfill. In fact, the stabilization step provides additional immobilization properties over the landfill alternative.

Disadvantages - The main disadvantage with the stabilization and off-site landfill alternative is an increased cost due to the greatly increased volume of materials to be landfilled with a minimal, relative increase in protection when compared to the landfill alternative alone. Also, this alternative requires additional worker handling, which increases the potential risk of worker exposure to the contaminated soils, and requires transport to the landfill, increasing the potential for accidents and additional exposure.

5.6.4 Alternative 7 - Excavation and Off-Site Incineration

Advantages - This alternative offers the advantages of PCB destruction, which in turn reduces the level of risk to nearby receptors.

000804

Disadvantages - The off-site incineration alternative exhibits the following disadvantages: high cost, possibility of an accidental release during transportation of the contaminated soils off-site, and availability of a facility in compliance with Superfund Off-Site Disposal Policy.

5.6.5 Alternative 8 - Excavation and On-Site Incineration

Advantages - This alternative demonstrates various advantages, such as destruction of the PCBs, a slight reduction of soil volume, and no transportation of the contaminated soils off-site to increase the potential for an environmental release.

Disadvantages - The on-site incineration alternative exhibits the following disadvantages: cost, availability of incineration units, and additional traffic and noise from the heavy equipment.

5.6.6 Alternative 10 - Excavation and Activated Sludge Treatment

Advantages - The activated sludge process offers the following advantages: innovativeness and destruction of the PCBs.

Disadvantages - The disadvantages of the alternative are time for implementation and the lack of many documented field scale tests.

5.6.7 Alternative 11 - Excavation and Contained Landfarm

Advantages - The advantages of the contained landfarm alternative are destruction of the PCBs and innovativeness.

Disadvantages - The disadvantages of this alternative include the long implementation time and lack of data proving the reliability on a field scale.

5
0
8
0
0
0

5.6.8 Alternative 12 - Excavation and Chemical Treatment

Advantages - The main advantage of this innovative remedial action is destruction of the PCBs, reducing the level of risk to nearby receptors, plus innovativeness.

Disadvantages - However, in situ chemical treatment exhibits the following disadvantages:

- Inhibition by excessive moisture and
- Not well proven reliability on a field scale (However, more pilot scale data exists for this alternative than for some of the other innovative remedial methods).

5.6.9 Alternative 15 - In Situ Glassification

Advantages - The in situ glassification alternative offers the following advantages:

- Innovativeness,
- Destruction of organic contaminants,
- Immobilization of inorganic constituents, and
- Increased worker protection through collection of off-gases and minimization of excavation and construction activities.

Disadvantages - The disadvantages associated with the in situ glassification option may include implementability, lack of a proven field scale implementation, scheduling of equipment from the only available vendor, and building foundation problems caused by changing soil volume during the glassification process.

000806

REFERENCES CITED

1. Ackerman, D.G. and R. Scofield. Guidelines for the Disposal of PCBs and PCB items by Thermal Destruction. EPA 68-02-3174, U.S. Environmental Protection Agency, Washington, D.C., 1981. 29 pp.
2. API. Land Treatment Practices in the Petroleum Industry. American Petroleum Institute, Washington, D.C., 1983.
3. API. The Treatability of Appendix VIII Constituents Present in Petroleum Wastes by Land Treatment: Second Draft. American Petroleum Institute. Washington, D.C., 1983.
4. Brown, K.W. and Associates. Hazardous Waste Land Treatment. EPA SW-874, U.S. Environmental Protection Agency, Municipal Environmental Research Laboratory, Cincinnati, Ohio, 1980.
5. Brunner, W., R.H. Sutherland, and D.D. Focht. "Enhanced Biodegradation of Polychlorinated Biphenyls in Soil by Analog Enrichment and Bacterial Inoculation." Journal of Environmental Quality, 1985, Volume 14, Number 3, p. 324-328.
6. Code of Federal Regulations: Protection of Environment, 40 CFR, Part 7090 to End. Office of the Federal Register, National Archives and Records Administration, U.S. Government Printing Office, Washington, D.C., 1986.
7. DeTox Industries, Inc. Company Profile. Sugarland, Texas, 1987.
8. Ebasco Services Incorporated. Crystal City Airport Site, Crystal City, Texas, Feasibility Study. Final Report. Prepared for the Texas Water Commission. July, 1987.
9. Exner, J.H. Detoxication of Hazardous Wastes. Ann Arbor Science Publishers, Ann Arbor, Michigan. 1982.
10. Fitzpatrick, V.F., C.L. Timmerman, and J.L. Buel. In-Situ Vitrification - A Candidate Process for In-Situ Destruction of Hazardous Waste. Presented at: 7th Superfund Conference. Washington, D.C., 1986. 19 pp.
11. Fuerst, Sherry. Personal Communication. U.S. Environmental Protection Agency, Dallas, Texas 1987.
12. Godfrey, K.A., Jr. "Municipal Refuse: Is Burning Best?" Civil Engineering, April, 1985, Volume 55, Number 4, p. 53-56.
13. Griffin, R., R. Clark, M. Lee, and E. Chian. Disposal and Removal of Polychlorinated Biphenyls in Soil. In: Land Disposal of Hazardous Waste, Proceedings of the 4th Annual Research Symposium. EPA SH-433, U.S. Environmental Protection Agency, Cincinnati, Ohio, 1978.

1080007

14. Iaconianni, J. Destruction of PCBs - Environmental Applications of Alkali Metal Polyethylene Glycolate Complexes. EPA-600/S2-85/108, U.S. Environmental Protection Agency, Cincinnati, Ohio, 1985. 3 pp.
15. Kane, J.E. and J.V. Mehta. Cleanup and Closure of a PCB Contaminated Pond. Presented at: 8th Annual Madison Waste Conference. Madison, Wisconsin, September 18-19, 1985. 7 pp.
16. Ogden Environmental Services. News Release: New Transportable Toxic Waste Disposal System Near Completion. Ogden Environmental Services, San Diego, California, October 30, 1987.
17. Radian Corporation. Remedial Investigation, Industrial Transformer Superfund Site. Draft Report. Prepared for the Texas Water Commission. November, 1987.
18. Reynolds, T.D. Unit Operations and Processes in Environmental Engineering. Wadsworth, Inc., Belmont, California, 1982.
19. Roberts, L. "Discovering Microbes with a Taste for PCBs". Science. August 28, 1987. pp. 975-977.
20. Rogers, C.J., A.J. Klee, A. Kornel, J.B. White, K.B. Leese, and A.C. Clayton. Interim Report on the Feasibility of Using UV Photolysis and APEG Reagent for Treatment of Dioxin Contaminated Soils. EPA - 600/S2-85/083, U.S. Environmental Protection Agency, Cincinnati, Ohio, 1985. 4 pp.
21. Rogers, C.J. A. Kornel, and R.L. Peterson. Mobile KPEG Destruction Unit for PCBs, Dioxins, and Furans in Contaminated Waste. Presented at: 13th Annual Research Symposium on Land Disposal, Remedial Action, Incineration, and Treatment of Hazardous Waste. Cincinnati, Ohio, May 6-8, 1987. 5 pp.
22. Stearns, Conrad and Schmid Consulting Engineers, Inc. Disposal of Polychlorinated Biphenyls (PCBs) and PCB-Contaminated Materials, Volume 2: Suggested Procedure for Development of PCB Spill Prevention Control and Countermeasure Plans. EPRI FP-1207, Volume 2, Electric Power Research Institute, Palo Alto, California, 1979. 138 pp.
23. Sworzyn, E.M. and D.G. Ackerman. Interim Guidelines for the Disposal/ Destruction of PCBs and PCB Items by Non-Thermal Methods. EPA-68-02-3174, U.S. Environmental Protection Agency, Washington, D.C., 1981. 19 pp.
24. U.S. Environmental Protection Agency. Appendix B Guidance of Feasibility Studies Under CERCLA. EPA-540/G-85-003, U.S. Environmental Protection Agency, Washington, D.C., 1985. 176 pp.
25. U.S. Environmental Protection Agency. Test Methods for Evaluating Solid Waste: Physical/Chemical Methods. EPA SW-846, U.S. Environmental Protection Agency, Office of Solid Waste and Emergency Response, Washington, D.C., 1986.

000000

APPENDIX A
SURFACE WATER ALTERNATIVE COSTS

608000

ALTERNATIVE 1 - NO ACTION

<u>Direct Activity Costs</u>	<u>Cost Basis</u>	<u>Unit Cost</u>	<u>Total Cost</u>
1. Retention Pond			\$ 0
2. Lab Analyses			\$ 0
3. Tanks			\$ 0
4. Site Restoration			\$ <u>0</u>
	Total Direct Costs		\$ 0
<u>Indirect Activity Costs</u>	<u>Cost Basis</u>	<u>Unit Cost</u>	<u>Total Cost</u>
1. Contingency	% of direct costs		\$ 0
2. Engineering/Design	% of direct costs		\$ 0
3. Administration/ Inspection	% of direct costs		\$ 0
4. Permitting	% of direct costs		\$ <u>0</u>
	Total Indirect Costs		\$ 0
			===
Total Capital Costs			\$ 0
<u>Annual Operation and Maintenance</u>			
1. Monitoring			\$ 0
2. Maintenance			\$ <u>0</u>
	Total Operation and Maintenance (Annual)		\$ 0
			===
TOTAL YEARLY COST			\$ 0

000810

ALTERNATIVE 2 - RETENTION, TESTING, AND DISCHARGE

<u>Direct Activity Costs</u>	<u>Cost Basis</u>	<u>Unit Cost</u>	<u>Total Cost</u>
1. Retention Pond			
- Soil (clean)	70 yd ³	\$5.00/yd ³	\$ 350
- Construction	8 hours	\$150/hr	\$ 1,200
- Off-Site Transport	20 yd ³ trucks	\$4.30/mile	\$ 193
15 miles	3 loads		
2. Lab Analyses	12 months	\$5,000/month	\$ 60,000
3. Above Ground Tank	10,000 gals.	\$6,000/tank	\$ 6,000
4. Site Restoration	% of direct costs	1%	\$ <u>684</u>
Total Direct Costs			\$ 68,427

<u>Indirect Activity Costs</u>	<u>Cost Basis</u>	<u>Unit Cost</u>	<u>Total Cost</u>
1. Contingency	% of direct costs	10%	\$ 6,843
2. Engineering/Design	% of direct costs	10%	\$ 6,843
3. Administration/ Inspection	% of direct costs	4%	\$ 2,737
4. Permitting	% of direct costs (\$1000 minimum)	0.5%	\$ <u>1,000</u>
Total Indirect Costs			\$ 17,423
Total Capital Costs			\$ 85,850

Annual Operation and Maintenance

1. Monitoring		\$ 0
2. Maintenance		\$ <u>12,000</u>
Total Operation and Maintenance (Annual)		\$ 12,000
TOTAL YEARLY COST		\$ 97,850

000811

ALTERNATIVE 3 - RETENTION, TESTING, BIOLOGICAL TREATMENT, AND DISCHARGE

<u>Direct Activity Costs</u>	<u>Cost Basis</u>	<u>Unit Cost</u>	<u>Total Cost</u>
1. Retention Pond			
- Soil (clean)	70 yd ³	\$5.00/yd ³	\$ 350
- Construction	8 hours	\$150/hr	\$ 1,200
- Off-Site Transport 15 miles	20 yd ³ trucks 3 loads	\$4.30/mile	\$ 193
2. Lab Analyses	12 months	\$5,000/month	\$ 60,000
3. Above Ground Tank	10,000 gals.	\$6,000/tank	\$ 6,000
4. Bioreactor (30yd ³)	12 loads/year	\$1,750/load	\$ 21,000
5. Site Restoration	% of direct costs	1%	\$ 896
	Total Direct Costs		\$ 89,639
<u>Indirect Activity Costs</u>	<u>Cost Basis</u>	<u>Unit Cost</u>	<u>Total Cost</u>
1. Contingency	% of direct costs	10%	\$ 8,964
2. Engineering/Design	% of direct costs	10%	\$ 8,964
3. Administration/ Inspection	% of direct costs	4%	\$ 3,586
4. Permitting	% of direct costs (\$1000 minimum)	0.5%	\$ 1,000
	Total Indirect Costs		\$ 22,514
			=====
Total Capital Costs			\$112,153
<u>Annual Operation and Maintenance</u>			
1. Monitoring			\$ 0
2. Maintenance			\$ 12,000
	Total Operation and Maintenance (Annual)		\$ 12,000
			=====
TOTAL YEARLY COST			\$124,153

000812

ALTERNATIVE 4 - RETENTION, TESTING, PHYSICAL TREATMENT, AND DISCHARGE

<u>Direct Activity Costs</u>	<u>Cost Basis</u>	<u>Unit Cost</u>	<u>Total Cost</u>
1. Retention Pond			
- Soil (clean)	70 yd ³	\$5.00/yd ³	\$ 350
- Construction	8 hours	\$150/hr	\$ 1,200
- Off-Site Transport	20 yd ³ trucks	\$4.30/mile	\$ 193
15 miles	3 loads		
2. Lab Analyses	12 months	\$5,000/month	\$ 60,000
3. Above Ground Tank	10,000 gals.	\$6,000/tank	\$ 6,000
4. Carbon Columns	13 disposable units	\$600/unit	\$ 7,800
5. Site Restoration	% of direct costs	1%	\$ 839
6. Dispose Columns			
- Transport	17yd ³ truck	\$4.30/mile	
- 700 miles	1 load		\$ 3,000
- Landfill	25 tons	\$181/ton	\$ 4,525
	Total Direct Costs		\$ 83,907
<u>Indirect Activity Costs</u>	<u>Cost Basis</u>	<u>Unit Cost</u>	<u>Total Cost</u>
1. Contingency	% of direct costs	10%	\$ 8,391
2. Engineering/Design	% of direct costs	10%	\$ 8,391
3. Administration/ Inspection	% of direct costs	4%	\$ 3,356
4. Permitting	% of direct costs (\$1,000 minimum)	0.5%	\$ 1,000
	Total Indirect Costs		\$ 21,138
			=====
Total Capital Costs			\$105,045
<u>Annual Operation and Maintenance</u>			
1. Monitoring			\$ 0
2. Maintenance			\$ 12,000
	Total Operation and Maintenance (Annual)		\$ 12,000
			=====
TOTAL YEARLY COST			\$117,045

000812

ALTERNATIVE 5 - RETENTION, TESTING, DISCHARGE TO POTW

<u>Direct Activity Costs</u>	<u>Cost Basis</u>	<u>Unit Cost</u>	<u>Total Cost</u>
1. Retention Pond			
- Soil (clean)	70 yd ³	\$5.00/yd ³	\$ 350
- Construction	8 hours	\$150/hour	\$ 1,200
- Off-Site Transport	20 yd ³ trucks	\$4.30/mile	\$ 193
15 miles	3 loads		
2. Lab Analyses	12 months	\$5,000/month	\$ 60,000
3. Above Ground Tank	10,000 gals.	\$6,000/tank	\$ 6,000
4. User Charge	72,000 gal/yr	\$20/1000 gal	\$ 1,440
5. Capacity Fee	One time	\$2776/each	\$ 2,776
6. Site Restoration	% of direct costs	1%	\$ <u>727</u>
	Total Direct Costs		\$ 76,686

<u>Indirect Activity Costs</u>	<u>Cost Basis</u>	<u>Unit Cost</u>	<u>Total Cost</u>
1. Contingency	% of direct costs	10%	\$ 7,269
2. Engineering/Design	% of direct costs	10%	\$ 7,269
3. Administration/ Inspection	% of direct costs	4%	\$ 2,907
4. Permitting	% of direct costs (\$1,000 minimum)	0.5%	\$ <u>1,000</u>
	Total Indirect Costs		\$ 18,445
			=====
Total Capital Costs			\$ 91,131

Annual Operation and Maintenance

1. Monitoring		\$ 0
2. Maintenance		\$ <u>12,000</u>
	Total Operation and Maintenance (Annual)	\$ 12,000
		=====
TOTAL YEARLY COST		\$103,131

000814

ALTERNATIVE 6 - RETENTION, TESTING, DEEP WELL INJECTION

<u>Direct Activity Costs</u>	<u>Cost Basis</u>	<u>Unit Cost</u>	<u>Total Cost</u>
1. Retention Pond			
- Soil (clean)	70 yd ³	\$5.00/yd ³	\$ 350
- Construction	8 hours	\$150/hour	\$ 1,200
- Off-Site Transport 15 miles	20 yd ³ trucks 3 loads	\$4.30/mile	\$ 193
2. Lab Analyses	12 months	\$5,000/month	\$ 60,000
3. Above Ground Tank	10,000 gals.	\$6,000/tank	\$ 6,000
4. Transport Liquids to Well	72,000 gal.	\$600/6000 gal	\$ 7,200
5. Dispose water via Injection Well	600,561 lb/yr	\$0.03/lb	\$ 18,017
6. Site Restoration	% of direct costs	1%	\$ <u>939</u>
	Total Direct Costs		\$ 93,899
<u>Indirect Activity Costs</u>	<u>Cost Basis</u>	<u>Unit Cost</u>	<u>Total Cost</u>
1. Contingency	% of direct costs	10%	\$ 9,390
2. Engineering/Design	% of direct costs	10%	\$ 9,390
3. Administration/ Inspection	% of direct costs	4%	\$ <u>3,756</u>
	Total Indirect Costs		\$ 22,536
			=====
Total Capital Costs			\$116,435
<u>Annual Operation and Maintenance</u>			
1. Monitoring			\$ 0
2. Maintenance			\$ <u>12,000</u>
	Total Operation and Maintenance (Annual)		\$ 12,000
			=====
TOTAL YEARLY COST			\$128,435

000815

APPENDIX B
SURFACE AND SHALLOW SUBSURFACE SOIL
REMEDIATION COSTS

000816

FACTORS

1. Distance	- Solid Waste (uncontaminated)	25 miles
	- PCB Landfill	700 miles
	- Incinerator	1070 miles
	- Injection Well	50 miles
	- RCRA Landfill	250 miles
2. Density	- Soil	100 lb/ft ³
	- Fluids	65 lb/ft ³
3. Capacity	- Dump Truck	20 yd ³
	- Scraper	15 yd ³
	- Tank Truck	6000 gal ³
	- Dump Trailer	17 yd ³
4. Landfill	- Depth	12 feet
	- Liner Thickness	3 feet
	- Liner Drainage Layer Thickness	1 foot
	- Cap Thickness	
	- Area	3/8 acre
	- Volume	7260 yd ³
- Adding 15% Expansion Factor	8350 yd ³	
5. Contaminated Soil To Be Excavated	- 3/4 Acre to 2' Depth	2480 yd ³
	- Adding 15% Expansion Factor	2850 yd ³
	- Weight	7,695,000 lbs
		3,848 tons
6. Rainfall	- Average	3.3 inches/month

000817

UNIT COSTS

1. Excavate	- Front End Loader - contaminated	\$ 5.00/yd ³
	- clean	\$ 1.80/yd ³
	- Scraper	\$11.00/yd ³
2. Transport	- Off-Site - Dump Truck	\$ 3.50/mile
	- Tank Truck	\$ 3.00/mile
	- Freight Truck	\$ 3.50/mile
	- On-Site - Dump Truck	\$80.00/trip
3. Landfill Liners	- Installed	\$ 5.00/ft ³
4. Landfill	- Off-Site Disposal Fee	
	- Contaminated-PCBs	\$181/ton
	- Uncontaminated	\$ 20/yd ³
5. Incineration	- Off-Site Disposal Fee	\$1000/ton
6. Lab	- For PCBs and TCE	\$125-400/sample
7. Well Injection	- Off-Site Disposal Fee	\$0.02-0.03/lb
8. Revegetation	- Restoration	\$ 6.00/100 ft ²
	- Maintenance - Annual	\$ 2.50/100 ft ²
9. Cap	- Clay - Capital Cost	\$1.75/ft ²
	- Maintenance - Annual	\$5,000/yr
	- Asphalt - Capital Cost	\$1.75/ft ²
	- Maintenance - Annual	\$5,000/yr
10. Monitoring		\$10,000/yr
11. Temporary Fencing	- Chain Link	\$6/Linear Foot

000818

ALTERNATIVE 1 - NO ACTION

<u>Direct Activity Costs</u>	<u>Cost Basis</u>	<u>Unit Cost</u>	<u>Total Cost</u>
1. Dismantling RI Decgn Pad			
- Excavate 1609 ft ³ contaminated soil	Excavated and Stockpiled	\$16/yd ³	\$ 960
- Off-Site transport 25 miles	1 load	\$4.30/mi/load	\$ 108
- Off-Site transport 700 miles	17 yd ³ /truck 3 loads	\$4.30/mi/load	\$ 9,030
- Off-Site disposal	43 yd ³	\$181/tgn	\$ 10,492
- Off-Site disposal	17 yd ³	\$20/yd ³	\$ 340
2. Well Plugging			
- Materials			\$ 700
- Equipment	6 hours	\$75.00/hr	\$ 450
3. Mobilization/Demobilization	2 days	\$500/day	\$ 1,000
4. Demurrage	4 hr/load 3 loads	\$60/hr	\$ <u>720</u>
	Total Direct Costs		\$ 23,800
<u>Indirect Activity Costs</u>	<u>Cost Basis</u>	<u>Unit Cost</u>	<u>Total Cost</u>
1. Contingency	% of direct costs	10%	\$ 2,380
2. Engineering/Design	% of direct costs	10%	\$ 2,380
3. Administration/ Inspection	% of direct costs	4%	\$ <u>952</u>
	Total Indirect Costs		\$ <u>5,712</u>
Total Capital Costs			\$ 29,512
<u>Annual Operation and Maintenance</u>			
1. Monitoring			\$ 10,000
2. Maintenance			\$ <u>0</u>
	Total Operation and Maintenance (Annual)		\$ 10,000
GRAND TOTAL - Present Worth with 4% Interest Rate			<u>\$202,432</u>

000819

ALTERNATIVE 4 - EXCAVATION AND OFF-SITE LANDFILL

<u>Direct Activity Costs</u>	<u>Cost Basis</u>	<u>Unit Cost</u>	<u>Total Cost</u>
1. Mob./Demobilization	% of direct cost	3.50%	\$ 51,850
2. Site Preparation	% of direct cost	2.50%	\$ 37,035
3. Excavate - 2850 yd ³ contaminated soil	Excavated and transported to stockpile	\$11/yd ³	\$ 31,350
4. Off-Site Transport - 700 miles	17 yd ³ truck 193 loads	\$4.30/mi for 193 loads	\$ 580,930
5. Landfill Costs	3848 tons soil	\$181/ton	\$ 696,488
6. Lab Analyses	1 month	\$10,000/mo	\$ 10,000
7. Site Restoration	% of direct costs	1%	\$ 14,814
8. Temporary Fence	800 linear feet	\$6/lin.ft.	\$ 4,800
9. Backfill Clean Soil	2850 yd ³	\$11/yd ³	\$ 31,350
10. RI Closure			
- Excavate 1609 ft ³ contaminated soil	Excavated and stockpiles	\$16/yd ³	\$ 960
- Off-site transport 25 miles	1 load	\$4.30/mile/load	\$ 108
- Off-site transport 700 miles	17 yd ³ truck 3 loads	\$4.30/mile/load	\$ 9,030
- Off-site disposal	43 yd ³	\$181/ton	\$ 10,492
- Off-site disposal	17 yd ³	\$20/yd ³	\$ 340
- Demurrage	4 hr/load 3 loads	\$60/hr	\$ 720
11. Well Plugging			
- Materials			\$ 700
- Equipment	6 hrs.	\$75/hr	\$ <u>450</u>
	Total Direct Costs		\$1,481,417

000820

ALTERNATIVE 4 - EXCAVATION AND OFF-SITE LANDFILL (Continued)

<u>Indirect Activity Costs</u>	<u>Cost Basis</u>	<u>Unit Cost</u>	<u>Total Cost</u>
1. Contingency	% of direct costs	10%	\$ 148,142
2. Engineering/Design	% of direct costs	10%	\$ 148,142
3. Administration/Inspection	% of direct costs	4%	\$ 59,257
4. Permitting	% of direct costs	0.5%	\$ <u>7,407</u>
	Total Indirect Costs		\$ <u>362,948</u>
Total Capital Costs			\$1,844,365
 <u>Annual Operation and Maintenance</u>			
1. Monitoring			\$ 10,000
2. Maintenance			\$ <u>0</u>
	Total Operation and Maintenance (Annual)		\$ <u>10,000</u>
GRAND TOTAL - Present Worth with 4% Interest Rate			\$2,017,285

000821

ALTERNATIVE 6 - EXCAVATION, STABILIZATION, AND OFF-SITE LANDFILL

<u>Direct Activity Costs</u>	<u>Cost Basis</u>	<u>Unit Cost</u>	<u>Total Cost</u>
1. Mob./Demobilization	% of direct cost	3.50%	\$ 84,364
2. Site Preparation	% of direct cost	2.50%	\$ 60,260
3. Excavate - 2850 yd ³ contaminated soil	Excavated and transported to stockpile	\$11/yd ³	\$ 31,350
4. Off-Site Transport - 700 miles	17 yd ³ truck 290 loads	\$4.30/mi	\$ 872,900
5. On-Site Transport - 9810 yd ³ soil from excavation for stockpiling	12 yd ³ truck	\$1.44/yd ³	\$ 14,126
6. Landfill Costs	5772 tons soil	\$181/ton	\$1,044,732
7. Lab Analyses	2 month excavation time	\$10,000/mo	\$ 20,000
8. Site Restoration	% of direct costs	2%	\$ 48,208
9. Temporary Fence	800 linear feet	\$6/lin.ft.	\$ 4,800
10. Backfill Clean Soil	2850 yd ³	\$11/yd ³	\$ 31,350
11. Cement Kiln Dust	1425 yd ³	\$60/yd ³	\$ 85,500
12. Cement Mixer - 10 yd ³ capacity	60 days		\$ 90,000
13. RI Closure			
- Excavate 1609 ft ³ contaminated soil	Excavated and stockpiles	\$16/yd ³	\$ 960
- Off-site transport 25 miles	1 load	\$4.30/mile/load	\$ 108
- Off-site transport 700 miles	17 yd ³ truck 3 loads	\$4.30/mile/load	\$ 9,030
- Off-site disposal	43 yd ³	\$181/ton	\$ 10,492
- Off-site disposal	17 yd ³	\$20/yd ³	\$ 340
- Demurrage	4 hr/load 3 loads	\$60/hr	\$ 720
14. Well Plugging			
- Material			\$ 700
- Equipment			\$ 450
Total Direct Costs			\$2,410,389

000822

ALTERNATIVE 6 - EXCAVATION, STABILIZATION, AND OFF-SITE LANDFILL (Continued)

<u>Indirect Activity Costs</u>	<u>Cost Basis</u>	<u>Unit Cost</u>	<u>Total Cost</u>
1. Contingency	% of direct costs	10%	\$ 241,039
2. Engineering/Design	% of direct costs	10%	\$ 241,039
3. Administration/Inspection	% of direct costs	4%	\$ 96,416
4. Permitting	% of direct costs	0.5%	\$ <u>12,052</u>
	Total Indirect Costs		\$ <u>590,546</u>
Total Capital Costs			\$3,000,935
<u>Annual Operation and Maintenance</u>			
1. Monitoring			\$ 10,000
2. Maintenance			\$ <u>0</u>
	Total Operation and Maintenance (Annual)		\$ <u>10,000</u>
GRAND TOTAL - Present Worth with 4% Interest Rate			\$3,173,855

000823

ALTERNATIVE 7 - EXCAVATION AND OFF-SITE INCINERATOR

<u>Direct Activity Costs</u>	<u>Cost Basis</u>	<u>Unit Cost</u>	<u>Total Cost</u>
1. Mob./Demobilization	% of direct cost	7.0%	\$ 318,551
2. Site Preparation	% of direct cost	5.0%	\$ 227,537
3. Excavate - 2850 yd ³ contaminated soil	Excavated and transported	\$11/yd ³	\$ 31,350
4. Off-Site Transport - 15 miles	17 yd ³ truck 168 loads	\$4.30/mi	\$ 10,836
5. Incineration - Incineration and ash disposal	3848 tons soils	\$1000/ton	\$3,848,000
6. Lab Analyses	1 month	\$10,000/mo	\$ 10,000
7. Site Restoration	% of direct costs	1%	\$ 45,507
8. Temporary Fence	800 linear feet	\$6/lin.ft.	\$ 4,800
9. Backfill Clean Soil	2850 yd ³	\$11/yd ³	\$ 31,350
10. RI Closure			
- Excavate 1609 ft ³ contaminated soil	Excavated and stockpiles	\$16/yd ³	\$ 960
- Off-site transport 25 miles	1 load	\$4.30/mile/load	\$ 108
- Off-site transport 700 miles	17 yd ³ truck 3 loads	\$4.30/mile/load	\$ 9,030
- Off-site disposal	43 yd ³	\$181/ton	\$ 10,492
- Off-site disposal	17 yd ³	\$20/yd ³	\$ 340
- Demurrage	4 hr/load 3 loads	\$60/hr	\$ 720
14. Well Plugging			
- Material			\$ 700
- Equipment			\$ 450
Total Direct Costs			\$4,550,731

000824

ALTERNATIVE 7 - EXCAVATION OFF-SITE INCINERATION (Continued)

<u>Indirect Activity Costs</u>	<u>Cost Basis</u>	<u>Unit Cost</u>	<u>Total Cost</u>
1. Contingency	% of direct costs	10%	\$ 455,073
2. Engineering/Design	% of direct costs	10%	\$ 455,073
3. Administration/Inspection	% of direct costs	4%	\$ 182,029
4. Permitting	% of direct costs	0.5%	\$ <u>22,754</u>
	Total Indirect Costs		<u>\$1,114,929</u>
Total Capital Costs			\$5,665,660
<u>Annual Operation and Maintenance</u>			
1. Monitoring			\$ 10,000
2. Maintenance			\$ <u>0</u>
	Total Operation and Maintenance (Annual)		<u>\$ 10,000</u>
GRAND TOTAL - Present Worth with 4% Interest Rate			\$5,838,580

000825

ALTERNATIVE 8 - EXCAVATION AND ON-SITE INCINERATION

<u>Direct Activity Costs</u>	<u>Cost Basis</u>	<u>Unit Cost</u>	<u>Total Cost</u>
1. Mob/Demobilization	% of direct cost	7.0%	\$ 111,537
2. Site Preparation	% of direct cost	5.0%	\$ 79,669
3. Excavate - 2850 yd ³ contaminated soils	Excavated and Transported	\$11/yd ³	\$ 31,350
4. Transport - on-site - move and backfill ash into excavation	2850 yd ³	\$20.57/yd ³	\$ 58,625
5. Incineration - load	1 loader-2850yd ³	\$26.86/yd ³	\$ 76,551
- grind	2850 yd ³ 3848 tons	\$16/ton	\$ 61,568
- incinerate/scrub	3848 tons soils/ 1000 tons process water	\$210/ton	\$1,018,080
6. Landfill - off-site disposal fee	100 yd ³ non-incinerable materials	\$370/yd ³	\$ 37,000
7. Backfill - on-site - clean soil into excavation	3630 yd ²	\$1.25/yd ²	\$ 4,538
8. Lab Analysis + TCLP	2 months	\$10,000/mo	\$ 20,000
9. Site Restoration and Ash Backfill	% of direct costs	2%	\$ 31,868
10. Temporary Fence	800 linear feet	\$6/lin.ft.	\$ 4,800
11. Test Burn	Per test	\$35,000/test	\$ 35,000
12. RI Closure			
- Excavate 1609 ft ³ contaminated soil	Excavated and stockpiled	\$16/yd ³	\$ 960
- Off-site Transport 25 miles	1 load	\$4.30/mi/load	\$ 108
- Off-site Transport 700 miles	17/yd ³ 3 loads	\$4.30/mi/load	\$ 9,030
- Off-site Disposal	17/yd ³	\$20/yd ³	\$ 340
- Off-site Disposal	43/yd ³	\$181/ton	\$ 10,492
- Demurrage	4hr/load 3 loads	\$60/hour	\$ 720

000826

ALTERNATIVE 8 - EXCAVATION AND ON-SITE INCINERATION (Continued)

<u>Direct Activity Costs</u>	<u>Cost Basis</u>	<u>Unit Cost</u>	<u>Total Cost</u>
13. Well Plugging			
- Materials			\$ 700
- Equipment	6 hours	\$75.00/hr	<u>\$ 450</u>
	Total Direct Costs		\$1,593,386
<u>Indirect Activity Costs</u>	<u>Cost Basis</u>	<u>Unit Cost</u>	<u>Total Cost</u>
1. Contingency	% of direct cost:	10%	\$ 159,339
2. Engineering/Design	% of direct cost:	10%	\$ 159,339
3. Administration/Inspection	% of direct cost:	4%	\$ 63,735
4. Permitting	% of direct cost:	0.5%	<u>\$ 7,967</u>
	Total Indirect Costs		<u>\$ 390,380</u>
Total Capital Costs			\$1,983,766
<u>Annual Operation and Maintenance</u>			
1. Monitoring			\$ 10,000
2. Site Maintenance			<u>\$ 0</u>
	Total Operation and Maintenance (Annual)		<u>\$ 10,000</u>
GRAND TOTAL - Present Worth with 4% Interest Rate			\$2,156,686

000827

ALTERNATIVE 10 - EXCAVATION AND ACTIVATED SLUDGE TREATMENT

<u>Direct Activity Costs</u>	<u>Cost Basis</u>	<u>Unit Cost</u>	<u>Total Cost</u>
1. Mob/Demobilization	% of direct cost	5.0%	\$ 116,050
2. Site Preparation	% of direct cost	2.5%	\$ 58,025
3. Excavation - 2850 yd ³ contaminated soil	Excavated and Transported	\$11/yd ³	\$ 31,350
4. RI Closure - Excavate 1609 ft ³ contaminated soil	Excavated and Transported	\$16/yd ³	\$ 960
- Off-Site Transport 25 miles	1 load	\$4.30/mi/load	\$ 108
- Off-Site Transport 700 miles	17 yd ³ truck 3 loads	\$4.30/mi/load	\$ 9,030
- Off-Site Disposal	17 yd ³	\$20/yd ³	\$ 340
- Off-Site Disposal	43 yd ³	\$181/ton	\$ 10,492
- Demurrage	4 hr/load 3 loads	\$60/hour	\$ 720
5. Well Plugging - Materials			\$ 700
- Equipment	6 hours	\$75.00/hr	\$ 450
6. Treatability Study	120 days	\$20,000/test	\$ 20,000
7. Bioreactor	2850 yd ³	\$700/yd ³	\$ 1,995,000
8. Backfill Clean Soil	2850 yd ³	\$11/yd ³	\$ 31,350
9. Site Restoration	% of direct costs	2%	\$ 46,420
Total Direct Costs			\$ 2,320,994

000828

ALTERNATIVE 10 - EXCAVATION AND ACTIVATED SLUDGE TREATMENT (Continued)

<u>Indirect Activity Costs</u>	<u>Cost Basis</u>	<u>Unit Cost</u>	<u>Total Cost</u>
1. Contingency	% of direct costs	10%	\$ 232,099
2. Engineering/Design	% of direct costs	10%	\$ 232,099
3. Administration/ Inspection	% of direct costs	4%	\$ 92,840
4. Permitting	% of direct costs	0.5%	\$ <u>11,605</u>
		Total Indirect Costs	\$ <u>568,643</u>
Total Capital Costs			\$ 2,889,637
 <u>Annual Operation and Maintenance</u>			
1. Monitoring			\$ 10,000
2. Maintenance			\$ <u>0</u>
		Total Operation and Maintenance (Annual)	\$ <u>10,000</u>
 GRAND TOTAL - Present Worth with 4% Interest Rate			\$ 3,062,557

000829

ALTERNATIVE 11 - EXCAVATION AND CONTAINED LANDFARM

<u>Direct Activity Costs</u>	<u>Cost Basis</u>	<u>Unit Cost</u>	<u>Total Cost</u>
1. Mob/Demobilization	% of direct costs	5.0%	\$ 86,270
2. Site Preparation	% of direct costs	2.5%	\$ 43,135
3. Excavate ³ - 2850 yd ³ contaminated soil	Excavated and Transported	\$11/yd ³	\$ 31,350
4. RI Closure			
- Excavate 1609 ft ³ contaminated soil	Excavated and stockpiled	\$16/yd ³	\$ 960
- Off-Site Transport 25 miles	1 load	\$4.30/mi/load	\$ 108
- Off-Site Transport 700 miles	17 yd ³ truck 3 loads	\$4.30/mi/load	\$ 9,030
- Off-Site Disposal	17 yd ³	\$20/yd ³	\$ 340
- Off-Site Disposal	43 yd ³	\$181/ton	\$ 10,492
- Demurrage	4hr/load (3 loads)	\$60/hr	\$ 720
5. Well Plugging			
- Materials			\$ 700
- Equipment	6 hrs	\$75/hr	\$ 450
6. Treatability Study	120 days	\$20,000/test	\$ 20,000
7. High Density Polyethylene liner (HDPE)	21,780 ft ²	\$0.50/ft ²	\$ 10,890
8. Tractor with tiller	12 months	\$2,500/mo	\$ 30,000
9. Site Restoration	% of direct costs	2%	\$ 34,508
10. Dump Truck (12 ton payload)	2 months	\$1,725/mo	\$ 3,450
11. Backhoe (2yd ³ cap.)	2 months	\$9,000/mo	\$ 18,000
12. Soil Treatment	2850yd ³	\$500/yd ³	<u>\$1,425,000</u>
	Total Direct Costs		\$1,725,403

000830

ALTERNATIVE 11 - EXCAVATION AND CONTAINED LANDFARM (Continued)

<u>Indirect Activity Costs</u>	<u>Cost Basis</u>	<u>Unit Cost</u>	<u>Total Cost</u>
1. Contigency	% of direct costs	10%	\$ 172,540
2. Engineering/Design	% of direct costs	10%	\$ 172,540
3. Administration/ Inspection	% of direct costs	4%	\$ 69,016
4. Permitting	% of direct costs	0.5%	\$ <u>8,627</u>
		Total Indirect Costs	\$ <u>422,723</u>
Total Capital Costs			\$2,148,126
 <u>Annual Operation and Maintenance</u>			
1. Monitoring			\$ 10,000
2. Maintenance			\$ <u>0</u>
		Total Operation and Maintenance (Annual)	\$ <u>10,000</u>
GRAND TOTAL - Present Worth with 4% Interest Rate			\$2,321,046

000831

ALTERNATIVE 12 - EXCAVATION AND CHEMICAL TREATMENT

<u>Direct Activity Costs</u>	<u>Cost Basis</u>	<u>Unit Cost</u>	<u>Total Cost</u>
1. Mob/Demobilization	% of direct cost	3.5%	\$ 49,706
2. Site Preparation	% of direct cost	5.5%	\$ 78,109
3. Treatment Costs	2850 yd ³ contaminated soil	\$300/yd ³	\$ 855,000
4. Lab Analyses	6 months	\$10,000/mo	\$ 60,000
5. Site Restoration	% of direct cost	2%	\$ 28,403
6. Temporary Fence	800 linear feet	\$6/lin.ft.	\$ 4,800
7. Excavate - 2850 yd ³ contaminated soil	Excavated and Transported to Stockpile	\$11/yd ³	\$ 31,350
8. Cement Mixer - 10yd ³ capacity	180 days		\$ 270,000
9. Treatability Study	120 days	\$20,000/test	\$ 20,000
10. RI Closure			
- Excavate 1609 ft ³ contaminated soil	Excavated and stockpiled	\$16/yd ³	\$ 960
- Off-Site Transport 25 miles	1 load	\$4.30/mi/load	\$ 108
- Off-Site Transport 700 miles	17 yd ³ 3 loads	\$4.30/mi/load	\$ 9,030
- Off-Site Disposal	17 yd ³	\$20/yd ³	\$ 340
- Off-Site Disposal	43 yd ³	\$181/ton	\$ 10,492
- Demurrage	4 hr/load (3 loads)	\$60/hr	\$ 720
11. Well Plugging			
- Materials			\$ 700
- Equipment	6 hours	\$75.00/hr	\$ 450
Total Direct Costs			\$1,420,169

000832

ALTERNATIVE 12 - EXCAVATION AND CHEMICAL TREATMENT

<u>Indirect Activity Costs</u>	<u>Cost Basis</u>	<u>Unit Cost</u>	<u>Total Cost</u>
1. Contingency	% of direct cost	10%	\$ 142,017
2. Engineering/Design	% of direct cost	10%	\$ 142,017
3. Administration/Inspection	% of direct cost	4%	\$ 56,807
4. Permitting	% of direct cost	0.5%	\$ 7,101
5. Shakedown	% of direct cost	1.5%	\$ <u>21,303</u>
		Total Indirect Costs	\$ <u>369,245</u>
Total Capital Costs			\$1,789,414
<u>Annual Operation and Maintenance</u>			
1. Monitoring			\$ 10,000
2. Site Maintenance			\$ <u>0</u>
		Total Operation and Maintenance (Annual)	\$ <u>10,000</u>
GRAND TOTAL - Present Worth with 4% Interest Rate			\$1,962,334

000833

ALTERNATIVE 15 - IN SITU GLASSIFICATION

<u>Direct Activity Costs</u>	<u>Cost Basis</u>	<u>Unit Cost</u>	<u>Total Cost</u>
1. Mob/Demobilization	% of direct costs	7.0%	\$ 57,109
2. Site Preparation	% of direct costs	5.5%	\$ 44,872
3. Vitrification - 2480 yd ³ contaminated soils		\$9/ft ³	\$ 602,640
4. Transport Liquids (Scrub Water)		\$600/6000 gal vacuum truck	\$ 4,800
5. Dispose Scrub Water Via Injection Well		\$0.03/lb	\$ 12,011
6. Lab Analyses	2 months	\$10,000/mo	\$ 20,000
7. Site Restoration	% of direct costs	2%	\$ 16,317
8. Temporary Fence	800 linear feet	\$6/lin.ft.	\$ 4,800
9. Backfill Clean Soil	500 yd ³	\$11/yd ³	\$ 5,500
10. Treatability Pilot		\$25,000/Test	\$ 25,000
11. RI Closure			
- Excavate 1609 ft ³ contaminated soil	Excavated and stockpiled	\$16/yd ³	\$ 960
- Off-Site Transport 25 miles	1 load	\$4.30/mi/load	\$ 108
- Off-Site Transport 700 miles	17/yd ³ 3 loads	\$4.30/mi/load	\$ 9,030
- Off-Site Disposal	17 yd ³	\$20/yd ³	\$ 340
- Off-Site Disposal	43 yd ³	\$181/ton	\$ 10,492
- Demurrage	4 hr/load (3 loads)	\$60/hr	\$ 720
12. Well Plugging			
- Materials:			\$ 700
- Equipment	6 hours	\$75.00/hr	\$ 450
Total Direct Costs			\$ 815,849

000834

ALTERNATIVE 15 - IN SITU CLASSIFICATION (Continued)

<u>Indirect Activity Costs</u>	<u>Cost Basis</u>	<u>Unit Cost</u>	<u>Total Cost</u>
1. Contingency	% of direct cost	10%	\$ 81,585
2. Engineering/ Design	% of direct cost	10%	\$ 81,585
3. Administration/Inspection	% of direct cost	4%	\$ 32,634
4. Permitting	% of direct costs	0.5%	\$ 4,079
5. Shakedown	% of direct costs	1.5%	\$ <u>12,238</u>
	Total Indirect Costs		\$ 212,121
Total Capital Costs			\$1,027,970
<u>Annual Operation and Maintenance</u>			
1. Monitoring			\$ 10,000
2. Maintenance			\$ <u>0</u>
	Total Operation and Maintenance (Annual)		\$ 10,000
GRAND TOTAL - Present Worth with 4% Interest Rate,			\$1,200,890

000835